

STONEGLASS®

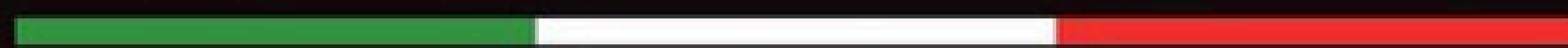

The new World

STONEGLASS® è stato creato per soddisfare le innumerevoli esigenze del mercato attuale. Nel corso della storia, l'uomo ha sempre cercato di scoprire o produrre nuovi materiali sulla base di tre fondamentali criteri: l'estetica, la versatilità e la reperibilità. Oggi siamo ad una svolta - oggi dobbiamo considerare un ulteriore criterio: l'impatto ambientale dei nostri materiali. STONEGLASS® è un nuovo materiale in grado di soddisfare tutti questi quattro criteri.

STONEGLASS® was created to satisfy many needs of today's material market. Throughout history, man has always strived to discover or manufacture, new materials based on three criteria: aesthetics, versatility and availability. Today we live at a turning point - now we must also consider an additional criteria the environmental impact of our materials. STONEGLASS® is a new material that satisfies all four of the criteria.

Marco Pietroni

STONEGLASS®

*Il marchio STONEGLASS® è sinonimo di qualità, caratteristica del Made in Italy.
Il marchio è registrato in tutto il mondo per garantire l'unicità e l'originalità dei nostri articoli.*

*The STONEGLASS® brand is synonymous with quality, a characteristic of the Made in Italy moniker.
The brand is registered around the world to assure the unique attributes of the material.*



*Company Profile
Find here our agents and distributors
around the world.*

Che cosa rende un progetto davvero memorabile?

La cura dei dettagli, la scelta dei materiali, la capacità di trasformare una visione in realtà. Un nuovo materiale, nato da una ricerca evolutiva e dalla volontà di superare i limiti, MICROGLASS è l'evoluzione di STONEGLASS: esclusivo e frutto della ricerca avanzata dell'azienda.

Realizzato attraverso un processo industriale che fonde e cristallizza a 1200°C silicio bianco purificato, MICROGLASS racchiude la traslucenza del cristallo e un bianco unico, insieme a caratteristiche strutturali superiori ai materiali lapidei.

Prodotto in grandi lastre e in vari spessori, MICROGLASS è realizzato e distribuito unicamente da STONEGLASS srl Italia, proprietaria del brevetto.

Un materiale d'avanguardia: perché ogni progetto di successo inizia dalla scelta giusta.

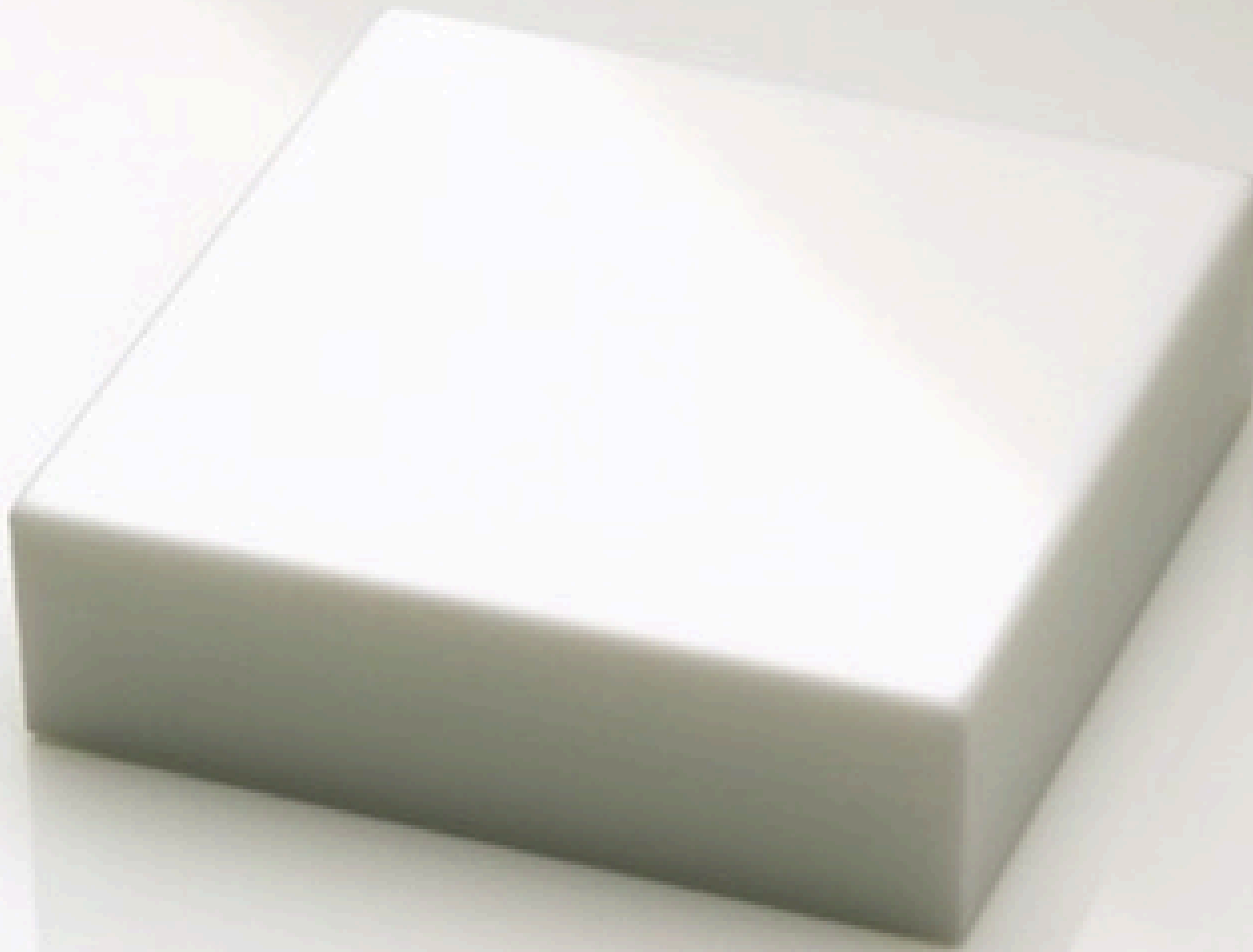

What makes a project truly memorable?

Attention to detail, the right choice of materials, and the ability to transform a vision into reality. A new material, born from evolutionary research and the ambition to push beyond existing limits, MICROGLASS is the evolution of STONEGLASS: an exclusive material resulting from the company's advanced research.

Produced through an industrial process that melts and crystallizes purified white silicon at 1200°C, MICROGLASS encapsulates the translucency of crystal and a distinctive white appearance, combined with structural properties superior to natural stone materials.

Manufactured in large slabs and various thicknesses, MICROGLASS is produced and distributed exclusively by STONEGLASS srl Italy, the sole owner of the international patent.

An innovative material—because every successful project begins with the right choice.

architettura perfetta

Perfect architecture

IL LOOK - la luce si diverte a disegnare forme sui suoi bordi. Riflette sulla superficie. Si tuffa e si confonde tra le sue trame. **STONEGLASS®** è elegante, ricco e moderno. La sua superficie lucida è totalmente riflettente. La sua finitura **MATT** è delicata. La versione **ANTISCIVOLO/BREEZE** è perfetta per i rivestimenti esterni e per i pavimenti. La sua versatilità è una qualità distintiva del design italiano.

THE LOOK - Light plays on the borders and edges. It reflects on the surfaces. It plunges into the textures. **STONEGLASS®** is chic, rich and modern. The **STONEGLASS®** polisher surface is reflective. The matte finish is subtle. The antislippery/breeze finish is perfect for outdoors and for flooring. This versatility is a signature quality of "Designed in Italy".



inside



BLACK
STONEGLASS, macrografia di uno speccato
STONEGLASS section view.

STONEGLASS® sposa le caratteristiche del vetro alle qualità della pietra. Il risultato finale è un nuovo e robusto elemento adatto ad una miriade di applicazioni. E' prodotto tramite un processo di fusione e cristallizzazione. Il processo è molto simile alle condizioni naturali di formazione del granito. Il suo aspetto è simile al marmo, ma con caratteristiche di durezza, lucentezza impermeabilità e resistenza superiori. STONEGLASS® non è un semplice vetro, è molto, molto di più.

STONEGLASS® marries the features of glass with the qualities of stone. The final result is a new, strong element - suited to a plethora of applications, it is manufactured through a process of melting and crystallization. The process is derived from the natural condition of granite formation. The look is similar to fine marbles but with superior hardness, brightness, imperviousness and resistance. STONEGLASS® is not a simple glass, it is so much more.

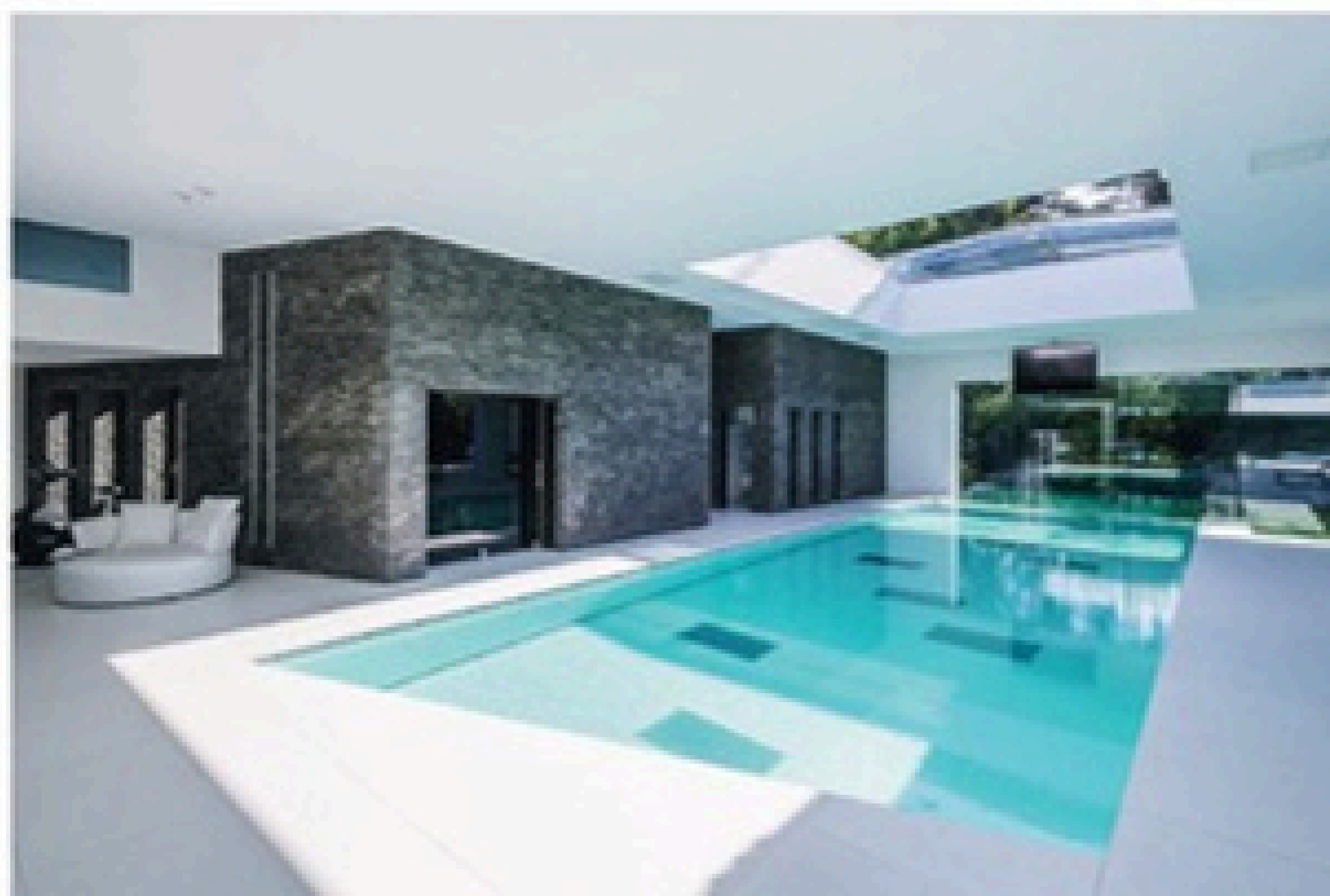
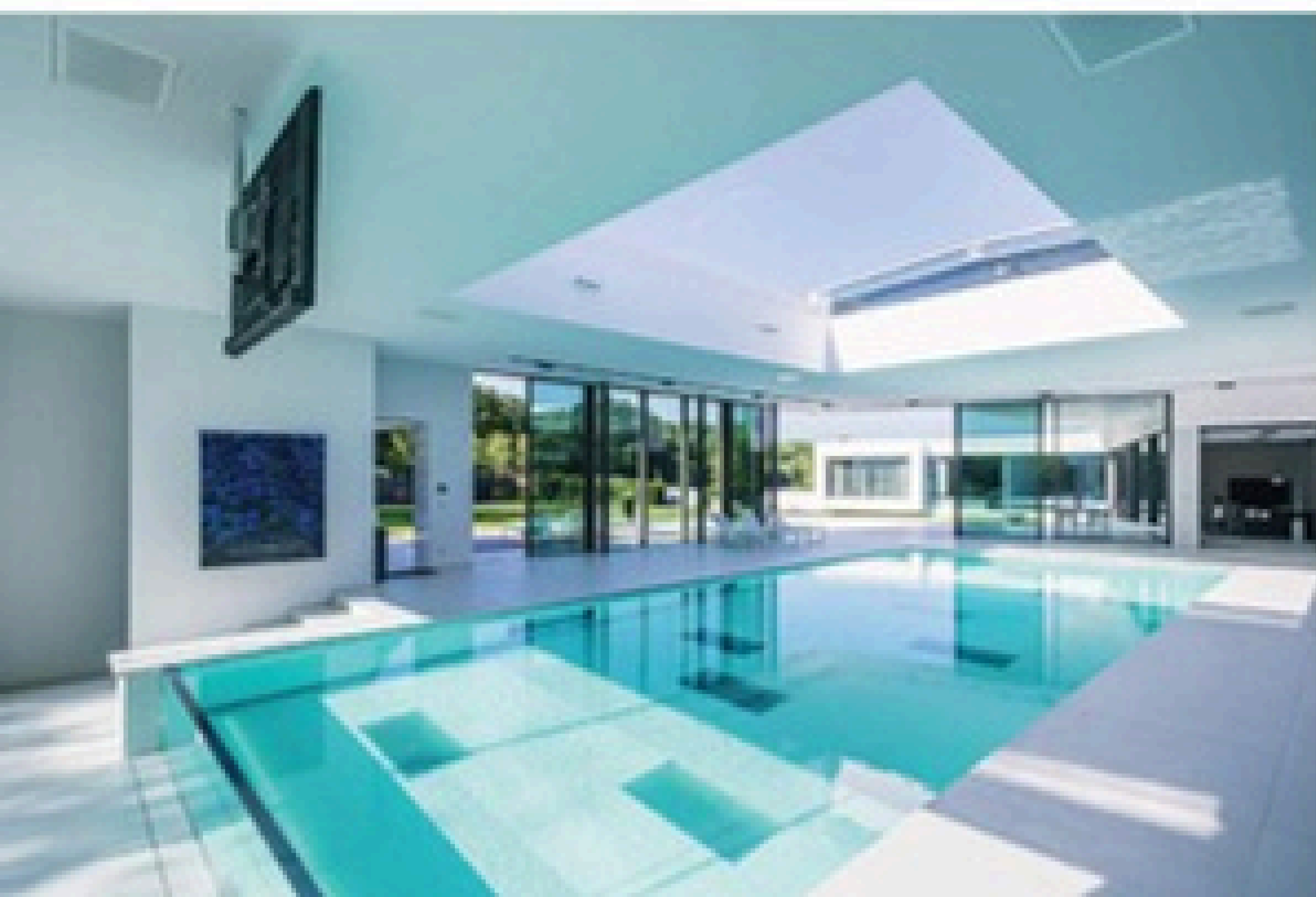

traslucente

Per scoprire cos'è STONEGLASS®, bisogna osservare come reagisce quando la luce lo attraversa. Chiudete gli occhi e immaginate un grattacielo. E' notte ma i suoi uffici sono ancora illuminati e nei corridoi si possono distinguere, come per magia, muoversi le sagome delle persone al suo interno.

L'inanimato che si anima e diventa vivo. Sovrapponendo le lastre e retro illuminandole, otteniamo effetti piacevoli e delicati!

To discover what's STONEGLASS® is, one must observe how it reacts when the light touches it. Close your eyes and dream of a skyscraper at night with lights on and movement inside its corridors. A lifeless thing becomes alive. By overlaying slabs and lighting them we achieve truly amazing effects!



Translucency presentation

ecologico

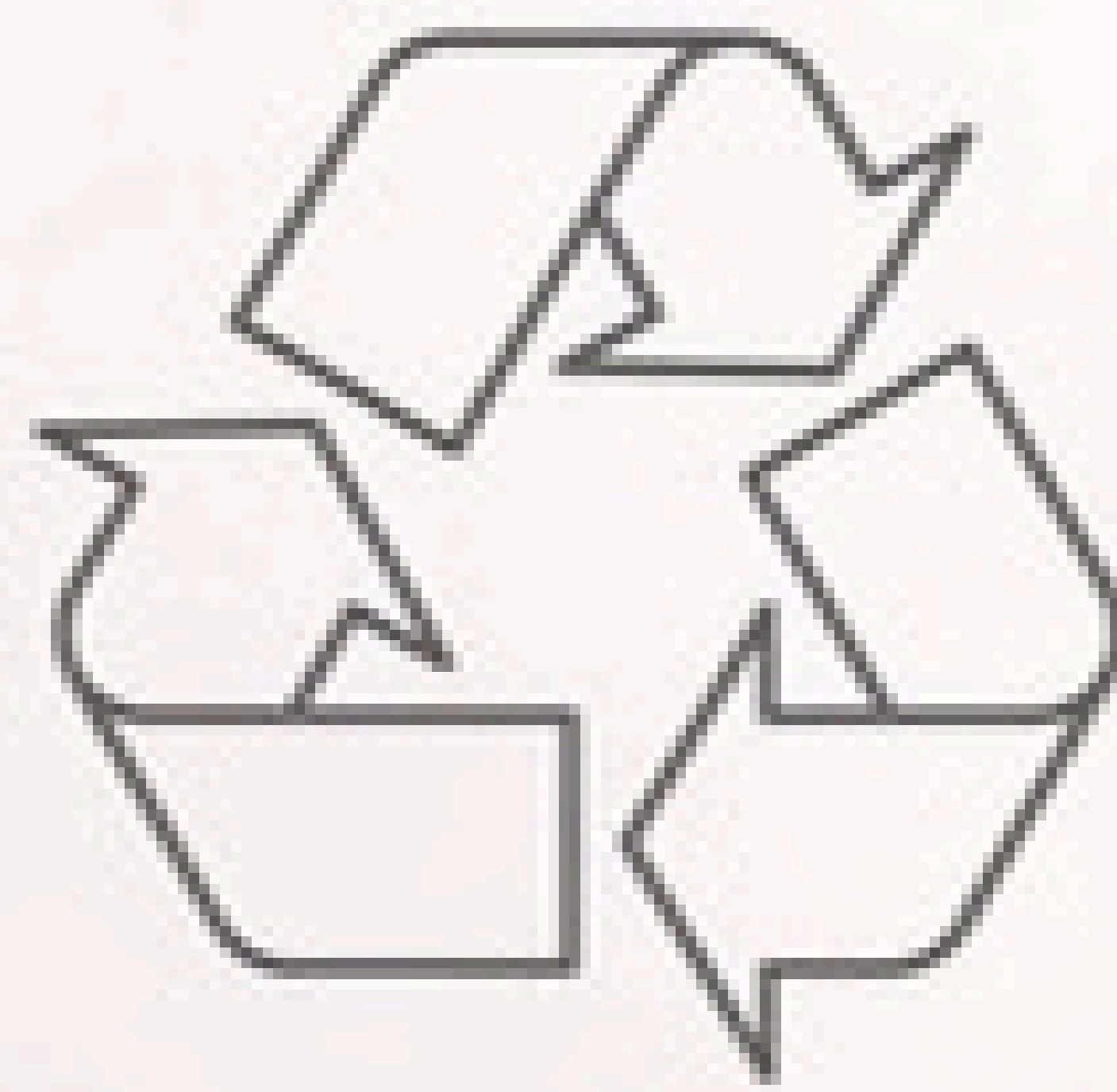

STONEGLASS® minimizza l'impatto ambientale a lungo termine. E' fatto di elementi naturali, senza resine o solventi al suo interno. E' completamente riciclabile.

STONEGLASS® minimizes long-term environmental impact. It is made from natural elements, without resin and without solvents. It is completely recyclable.



FORTE - Altamente resistente ai graffi - Resistente alle macchie.
STONEGLASS® è una soluzione per la bellezza che dura nel tempo.
Test rigorosi e analisi di laboratorio garantiscono le sue qualità.



Video Test Strong

STONEGLASS® is highly resistant to scratches – it is resistant to staining.
STONEGLASS® is a solution for long-term beauty.
Rigorous testing and laboratory analysis guarantee its qualities.



**FORTE - Altamente resistente ai graffi - Resistente alle macchie.
STONEGLASS® è una soluzione per la bellezza che dura nel tempo.
Test rigorosi e analisi di laboratorio garantiscono le sue qualità.**



Video Test Strong

STONEGLASS® is highly resistant to scratches – it is resistant to staining.
STONEGLASS® is a solution for long-term beauty.
Rigorous testing and laboratory analysis guarantee its qualities.







**Non è magia. STONEGLASS è il materiale perfetto per i piani a induzione invisibili.
Potrai cucinare direttamente sul piano STONEGLASS: non si macchia, non brucia.**

*It's not magic. STONEGLASS is the perfect material for INVISA COOK invisible induction hobs.
You will be able to cook directly on the STONEGLASS hob, it does not stain or burn.*





*ovunque
everywhere*

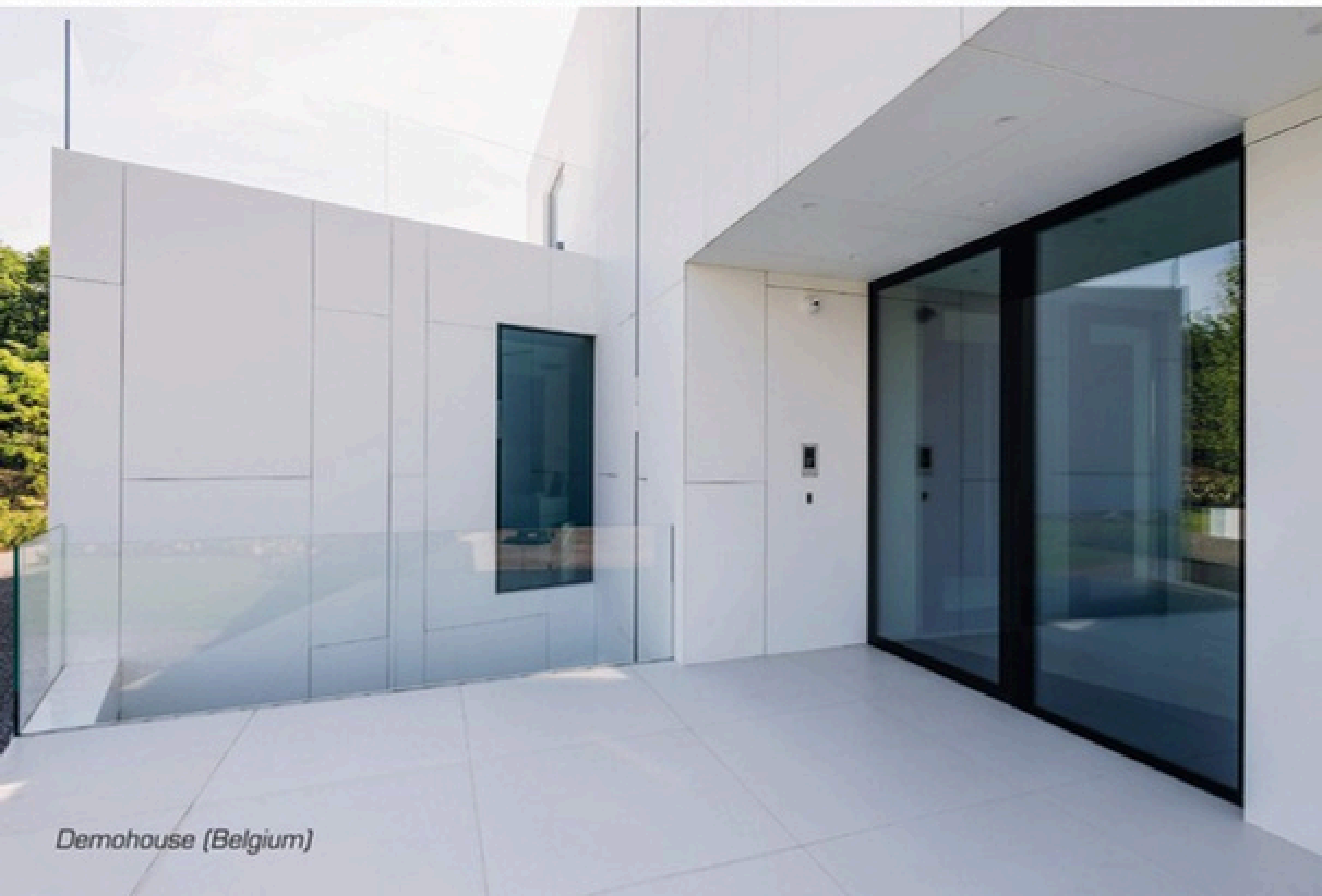

Demohouse (Belgium)



Dovunque

STONEGLASS® può essere usato all'esterno e all'interno, per pavimenti e pareti. Per piani lavoro, colonne e mobili eleganti, moderni o classici: STONEGLASS® può soddisfare infinite richieste.



Everywhere

STONEGLASS® can be used outdoor and indoor, for Floors and walls. It can be used for countertops, columns, and elegant furniture, modern or classic: STONEGLASS® can satisfy many demands.

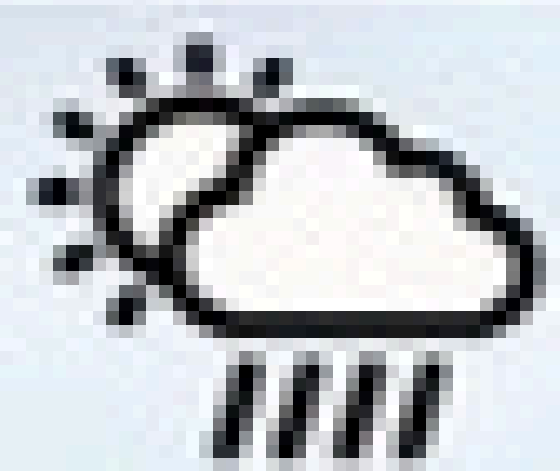

**Weather
Resistant**



**UV
RESISTANT**



Rainproof

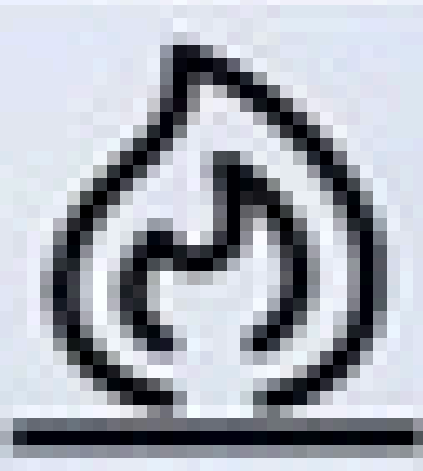

**Fire
Resistant**

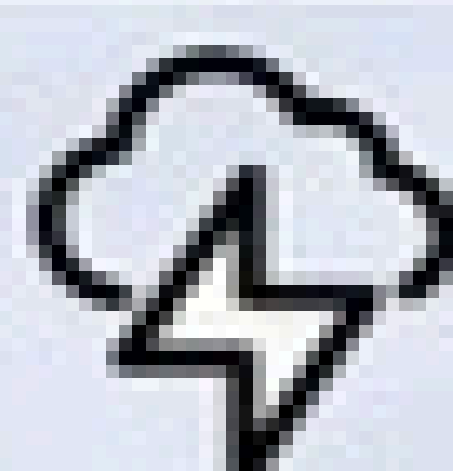

**Storm
Resistant**



*Sport Hall
Sochi Russia*

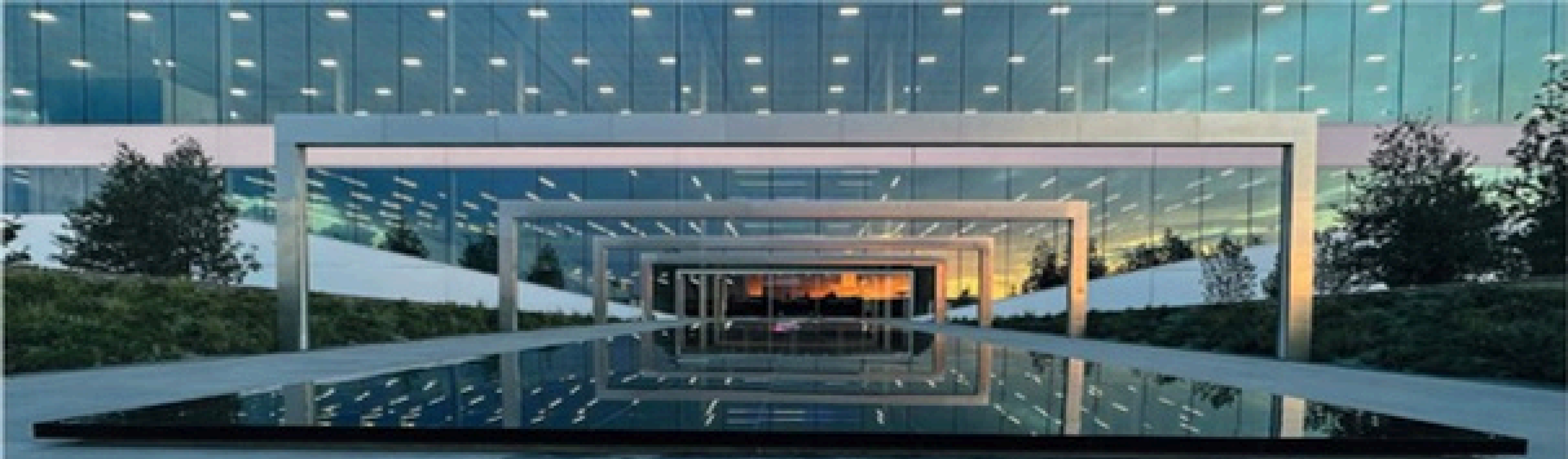

Tesla Gigafactory Texas USA

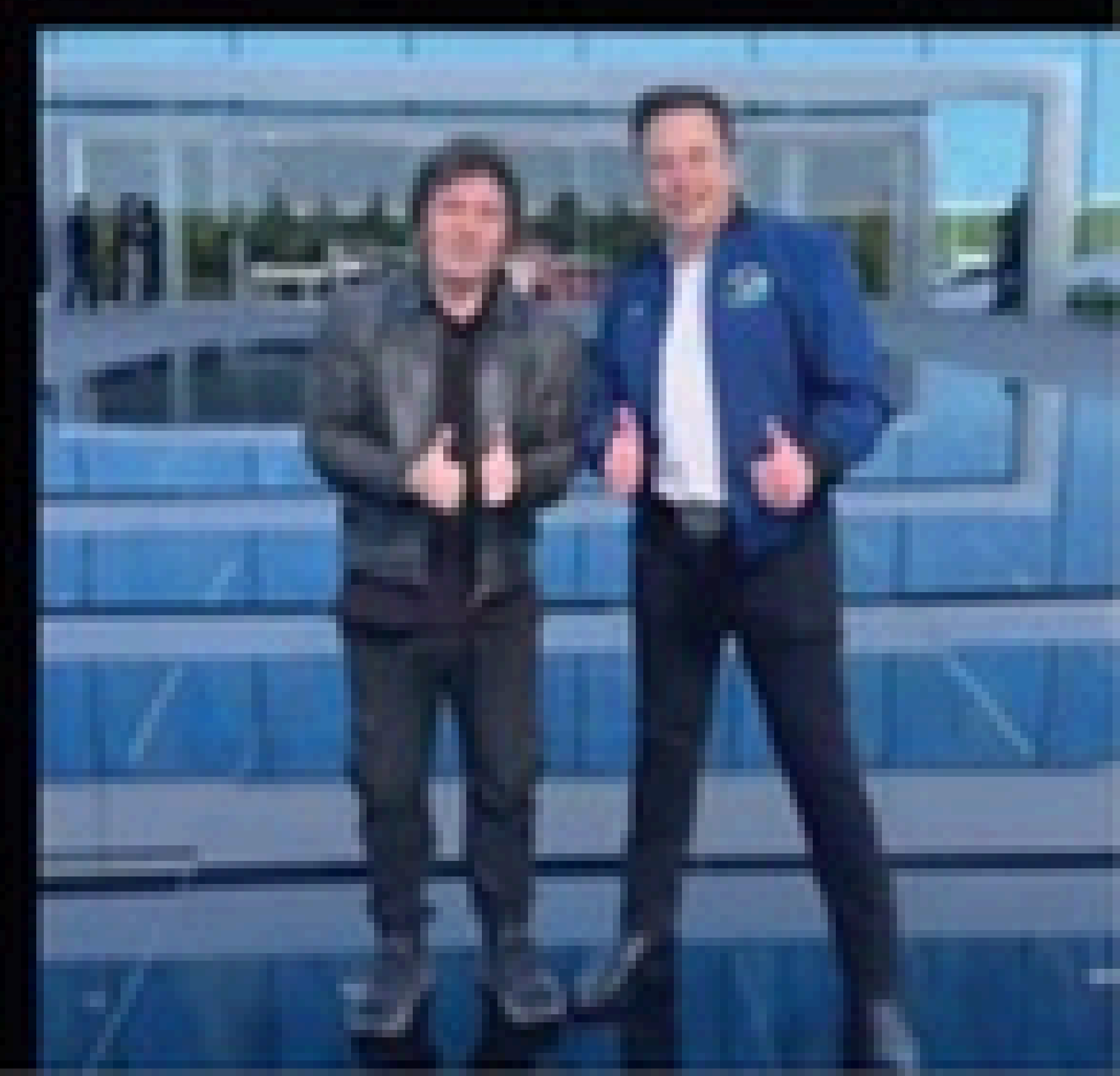

Facciate ventilate

ventilated facades

strumenti per l'edilizia

La scelta migliore

The best choice

Test di laboratorio suggeriscono che **STONEGLASS®** è una perfetta soluzione per le facciate ventilate esterne: è omogeneo, durevole, resistente alle sostanze acide e alcaline, resistente ai raggi UV e completamente riciclabile.

*Laboratory tests suggest that **STONEGLASS®** is the perfect solution for outdoor ventilated facades: it is homogeneous, durable, acid and alkaline resistant, UV resistant, and fully recyclable.*

Installazione perfetta, risultato garantito: Stoneglass® in opera con i nostri partner certificati

Perfect installation, guaranteed result: Stoneglass® in action with our certified partners



Video FISCHER FZP
Anchoring System
for Facades

Nelle immagini:
pannelli **STONEGLASS®**
finitura
bianco lucido su struttura
portante
Structure Easy in profilato di
alluminio e tasselli per
fissaggio
FZP entrambi sviluppati da
FISCHER.

Pictures:

*STONEGLASS® panels glossy
white finish fixed to Structure
Easy:
aluminum profile and anchor
bolts FZP are both developed by
FISCHER.*

Tassello FZP



STONEGLASS® vuole essere sinonimo di qualità, sempre, e si affida solo ai migliori partner. Per questo consiglia le soluzioni ed i fissaggi **FISCHER** leader mondiale del settore.

STONEGLASS® means quality and rely on the best partners. STONEGLASS recommends FISCHER the world leader of fastening systems.

fischer



Demohouse (Belgium)

STONEGLASS®

facciate ventilate

I nostri progetti
Our projects

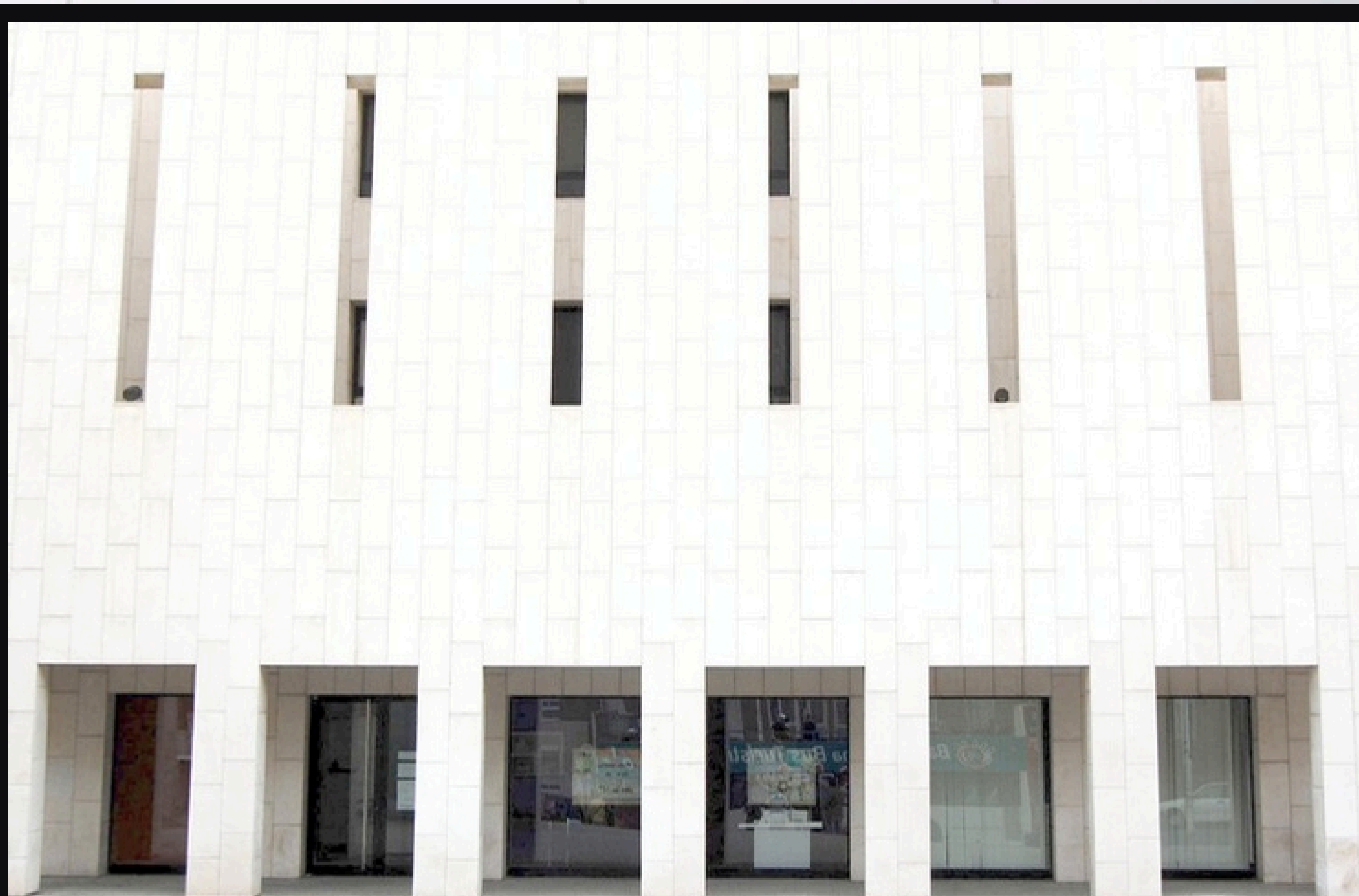
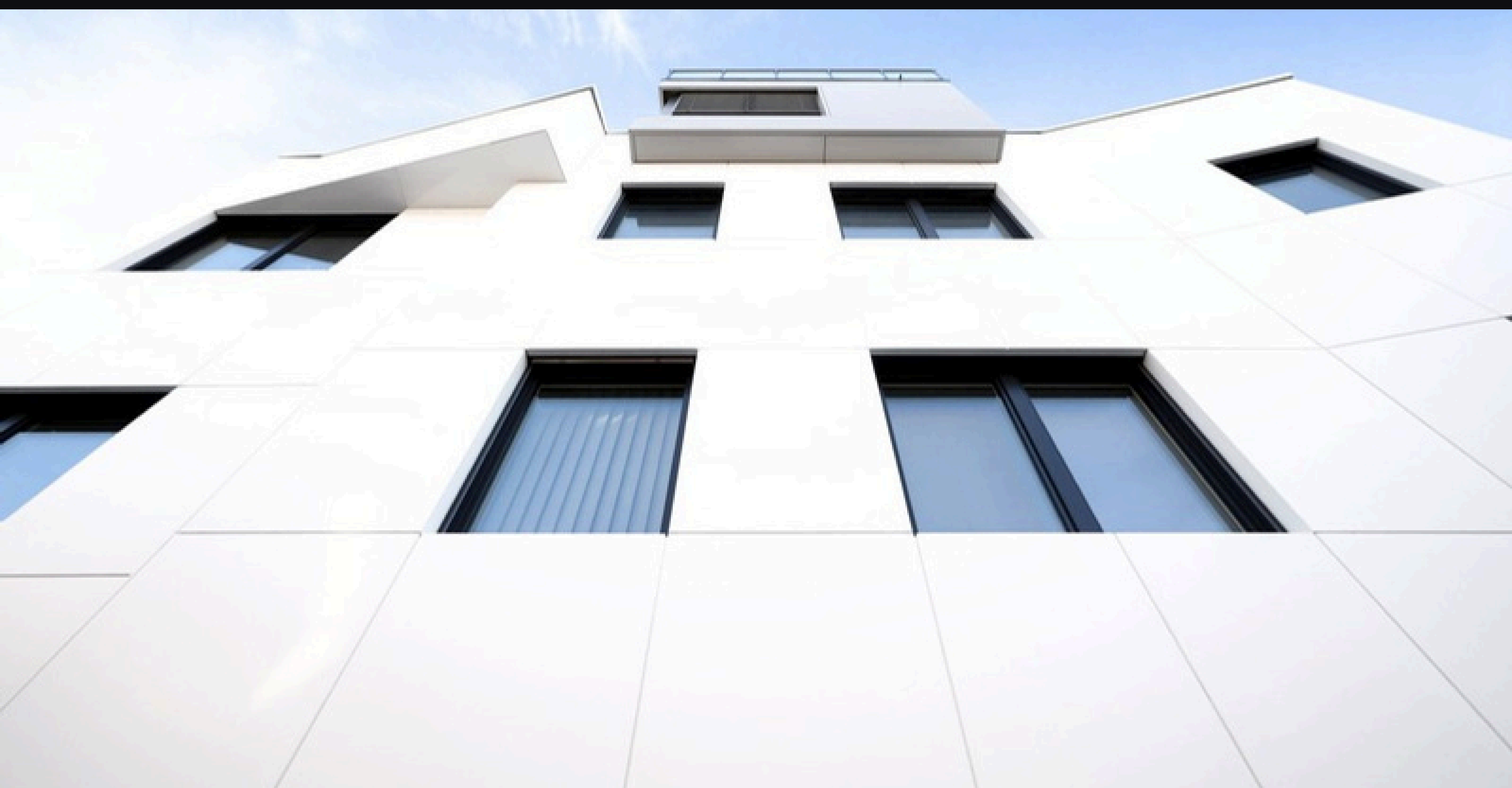



Angasana
Residences
Yeouido
Seoul

More projects here



Angasana Yeouido Residence (Seoul)



STONEGLASS®

Progetti di spessore in tutto il mondo:
STONEGLASS® è il materiale per eccellenza
nella progettazione e realizzazione di facciate
ventilate.

*Our projects worldwide: STONEGLASS® is the
material per excellence in the design and
construction of ventilated facades*



progettabilità dello spazio infinita

Sono sempre più numerosi i progetti che coinvolgono STONEGLASS®. Che si tratti di architetture in fase di studio oppure di realizzazioni già finite o in corso d'opera. Le sue qualità estetiche e le garanzie sulla solidità offerte dalla materia hanno impressionato positivamente un mercato in continua evoluzione, esigente e selettivo. STONEGLASS® è la soluzione definitiva.

INFINITE SPACE DESIGN - More and more projects are being made using STONEGLASS® be it architectural. Architectures in progress or real features. Its qualities in terms of beauty and solidity can respond to the demands of the most demanding consumer. STONEGLASS® is the ultimate solution.







STONEGLASS®

infinite forme
infinite shapes



termoformatura

I pannelli di STONEGLASS® possono essere CURVATI. Le peculiarità del materiale consentono di realizzare forme sinuose ed aggraziate.

THERMOFORMING – STONEGLASS® panel can be CURVED. The characteristics of the material allow post forming for exotic shapes and graceful waves.

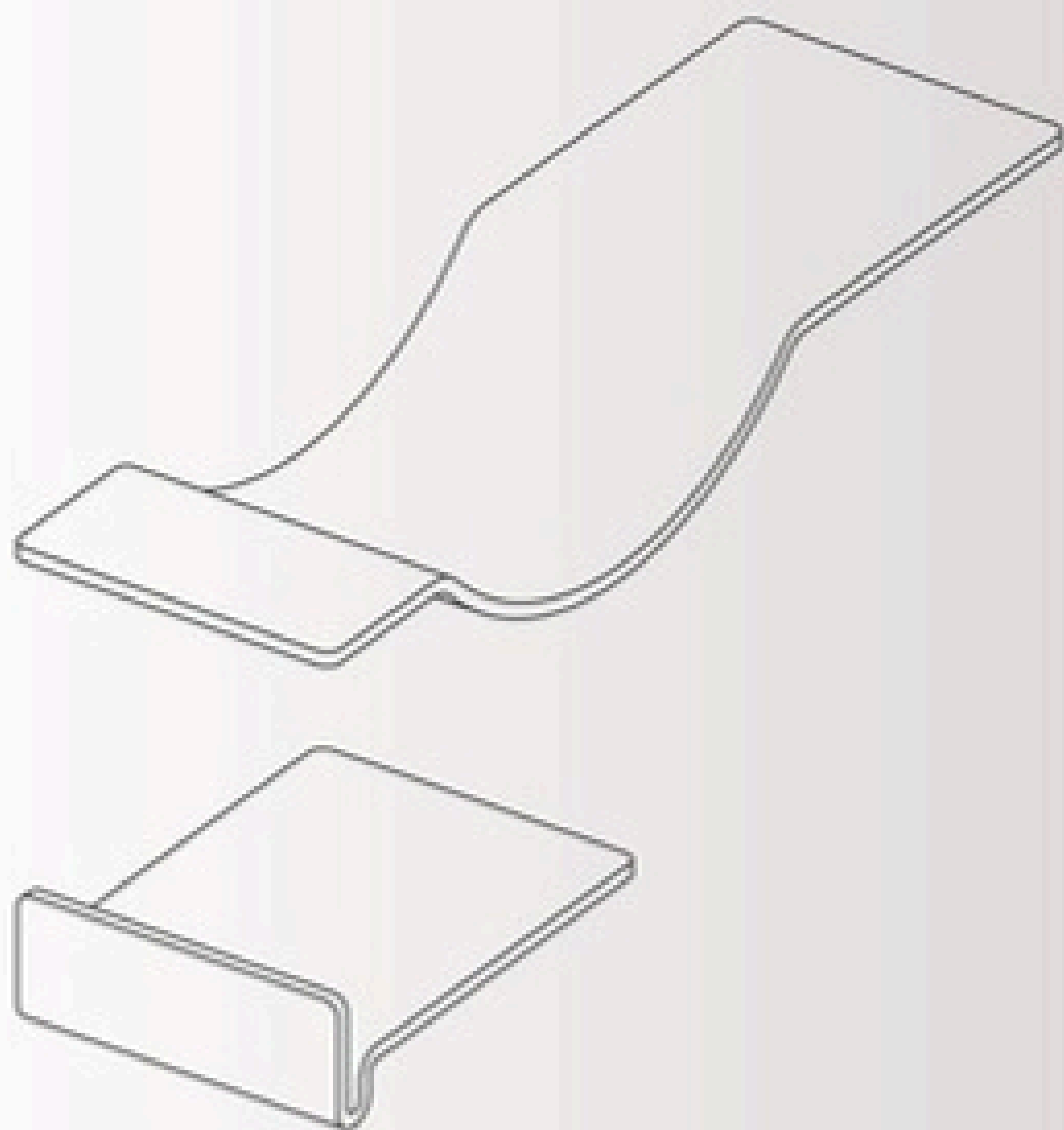

nel bagno

Piani da appoggio, lavabi, piani termocurvatî con lavabo integrato, rivestimenti doccia e vasca di ogni dimensione e forma. Ogni soluzione può essere realizzata su misura per assecondare e soddisfare anche le richieste più esigenti.

BATHROOM - Tops, sinks, thermoformed vanities with integrated sinks, shower walls and tub decks of any size and shape. Any unit can be custom sized to respond to the needs of the most demanding designs.





Top bagno STONEGLASS bianco lucido con lavabo integrato
 High glossy white STONEGLASS top with integrated sink.

Top bagno completo di lavabo STONEGLASS semi-incassato
 Top with built-in STONEGLASS sink

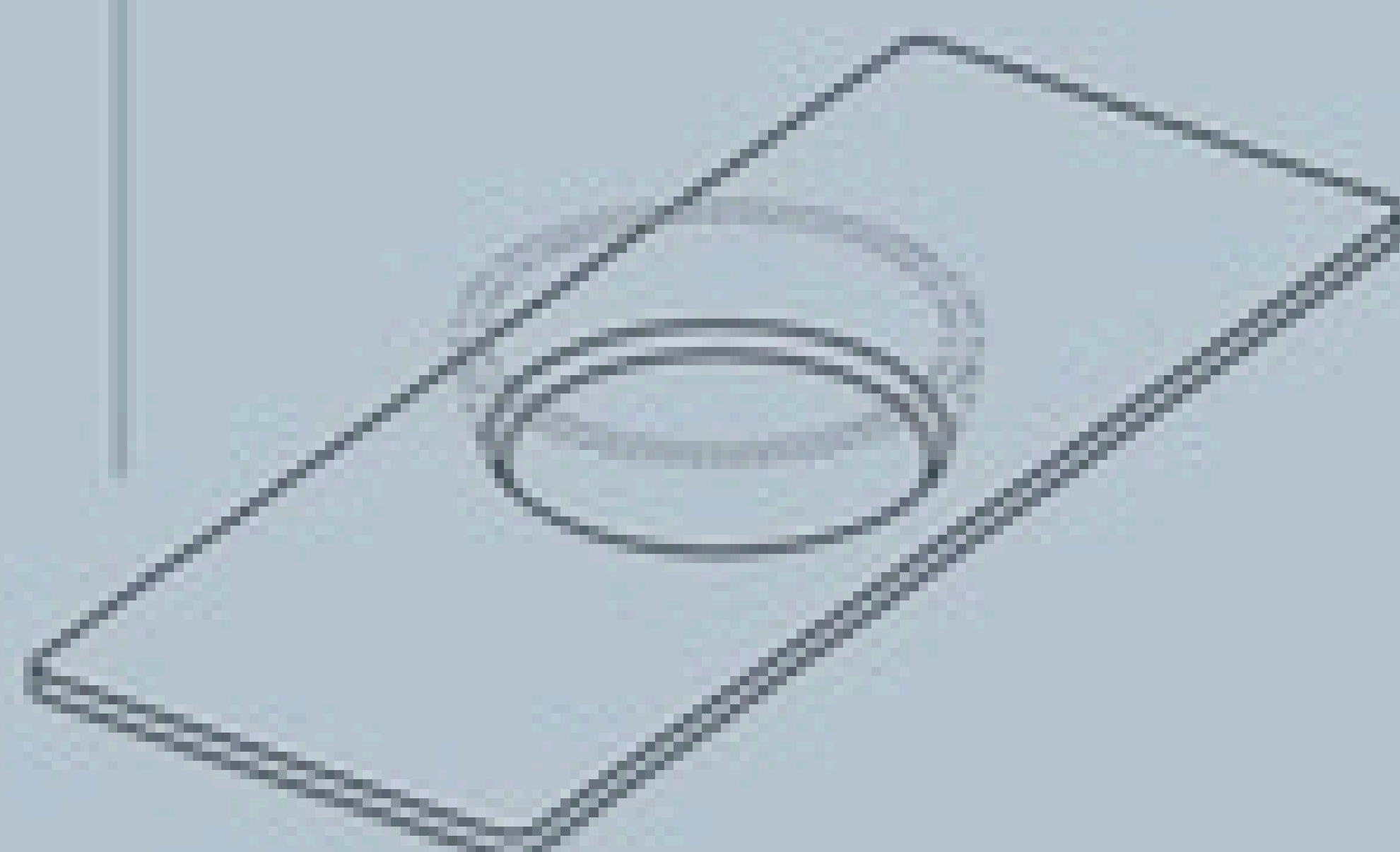

Top bagno con foro predisposizione lavabi filo-top o sotto-top
 Top with drill for sinks (flush to the top or undertop)

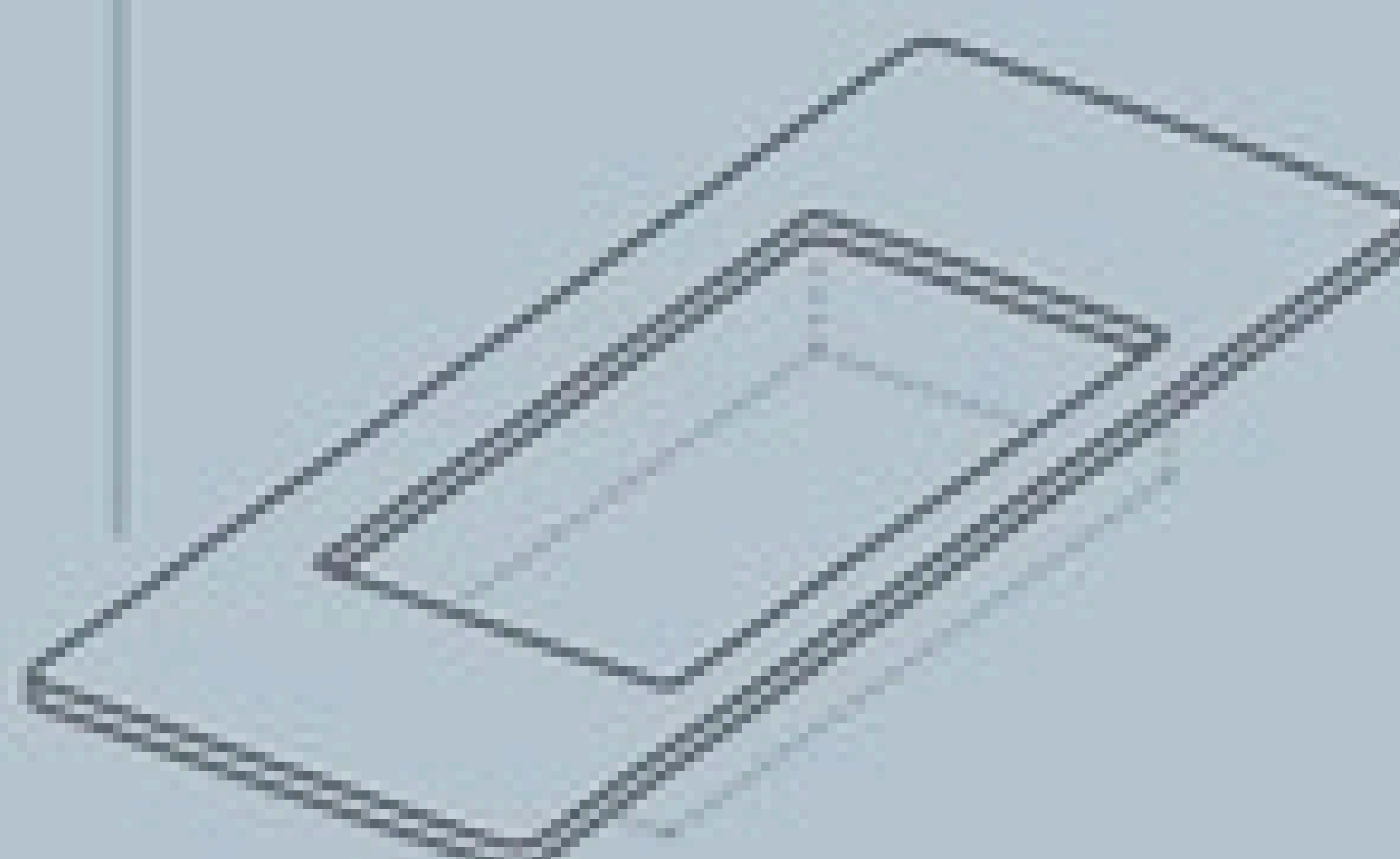

Top bagno termoformato con lavabo STONEGLASS da appoggio
 Thermoforming top with STONEGLASS sink

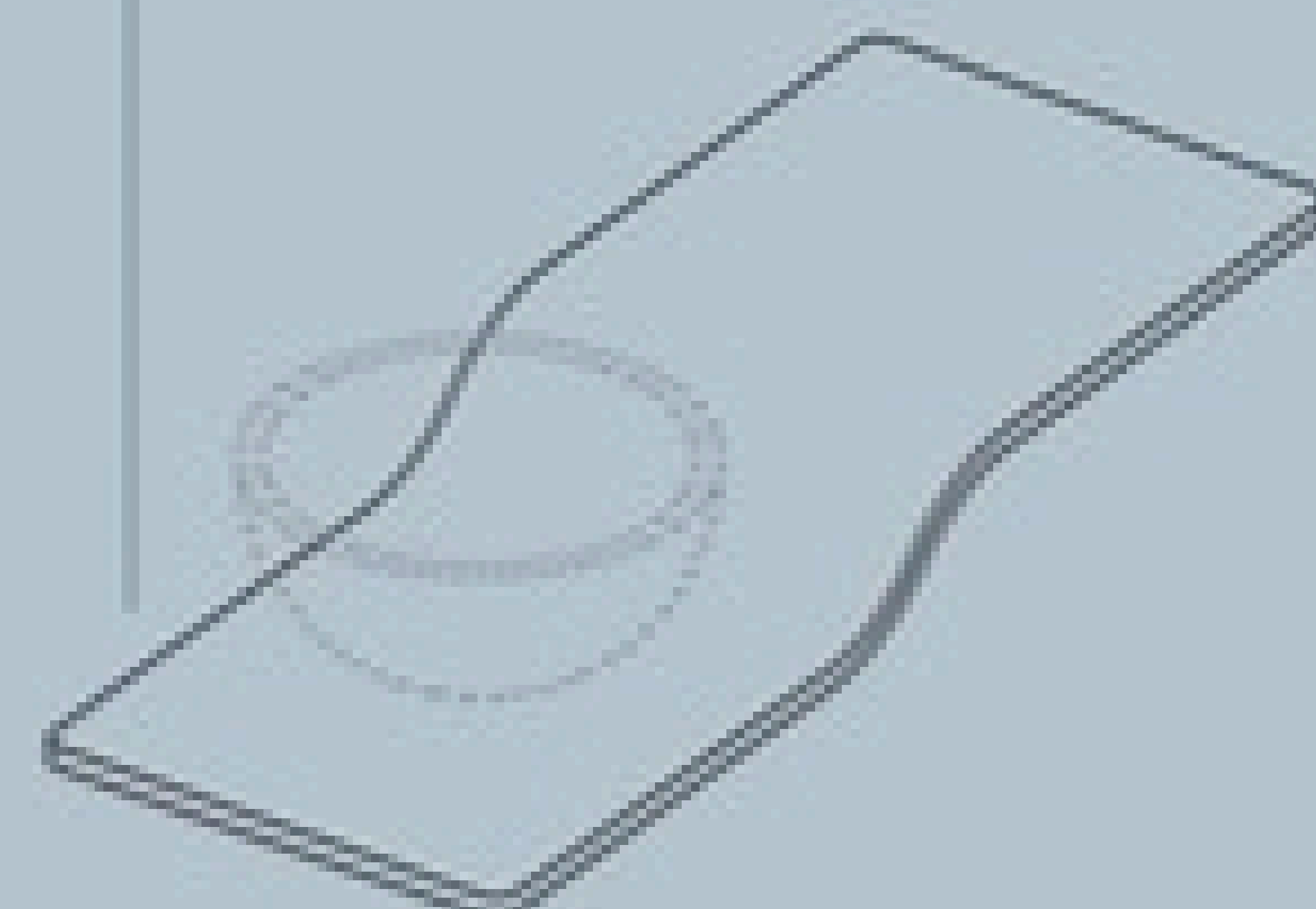



3D

E uno degli ultimi nati nella famiglia STONEGLASS®. La versione 3D Statuario nasce da un supporto di STONEGLASS® trattato digitalmente con tecnologia ink-jet. LO STONEGLASS® 3D mantiene le qualità del vetro (non assorbe, non si macchia, non ha porosità ed è curvabile) e le unisce alla bellezza e al fascino del marmo con una risoluzione estremamente fotorealistica.

It's one of the newest members of the STONEGLASS® family. The 3D Statuario version is born from a support of STONEGLASS®, digitally treated with ink-jet technology.

3D maintains the qualities of glass (it doesn't absorb, doesn't stain, has no porosity and is bendable) and combines them with the beauty and charm of marble with an extremely photorealistic resolution.

STONEGLASS®

3D

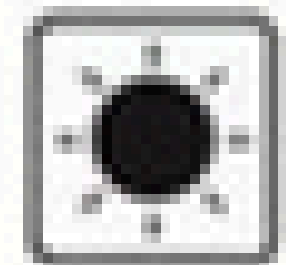

High Glossiness

Our material has not only a special crystallized structure, but also a special glass matrix structure. Its texture is delicate and its surface is crystal and bright. And it can produce a diffusive reflection effect for absorbing light.

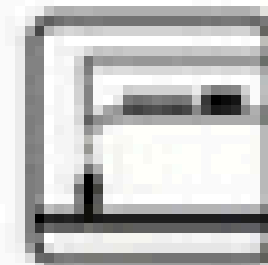

Acid & Alkali Resistance

3D crystallized glass has extremely high corrosion resistance, acid and alkali resistance, the color will not fade off, strength stays same after a long period.

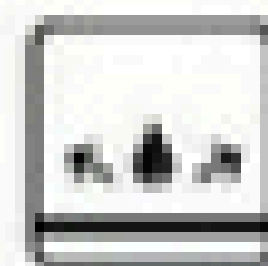

Zero Water Absorption

The water absorption rate is almost zero: 0.004%. Oil, stains and other liquids will not penetrate into the interior. No dirt absorption, which makes it easy and convenient to be cleaned.

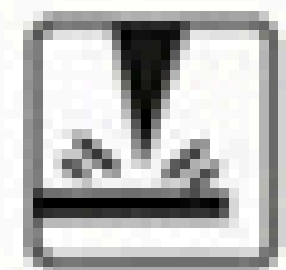

High Wear Resistance

The molecular micro-grain size reaches nanometer level. Fibrous crystal molecular structure achieves excellent materials with high compressive strength, which is easy for edge design and processing, such as circular cutting, drilling, sculpture and 45 degree cutting.

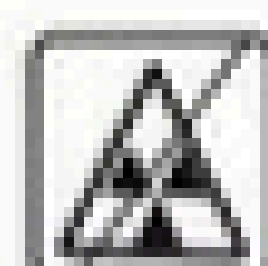

Zero Radiation

Non-radioactive, environmental friendly and reusable.

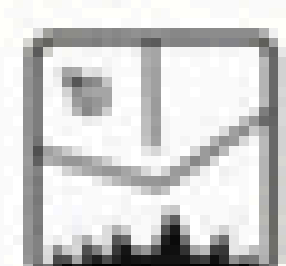

Good Temperature Resistance

3D crystallized glass can withstand the temperature range from -18°C to 800°C without any effects on the structure, color and shape.

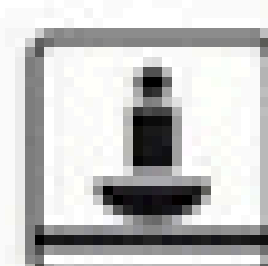

Hot Bendable

3D Crystallized glass can be made into various curved shapes by heating method. It has the advantages of simple process and reasonable cost, avoiding the disadvantages of normal stones such as difficulties in curved shaping, longer processing time, much materials waste etc.



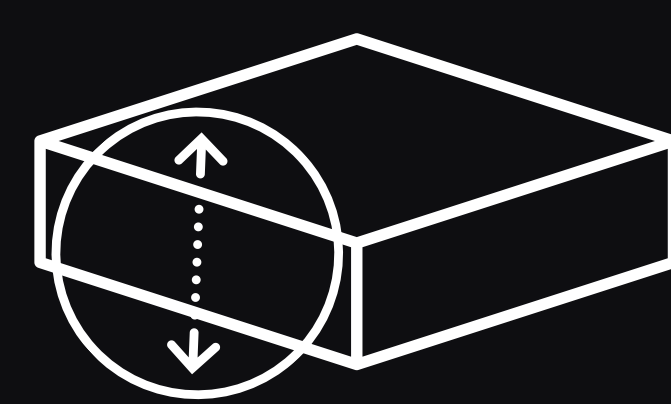

THICKNESS

5-10-18
mm

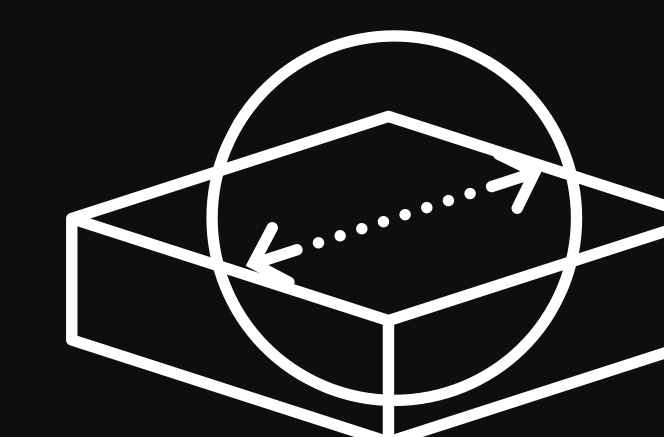

**MAX WIDTH
& LENGHT**

3060x1640
mm



**Weather
Resistant**



**UV
RESISTANT**



Rainproof



**Fire
Resistant**



**Storm
Resistant**

Slabs:

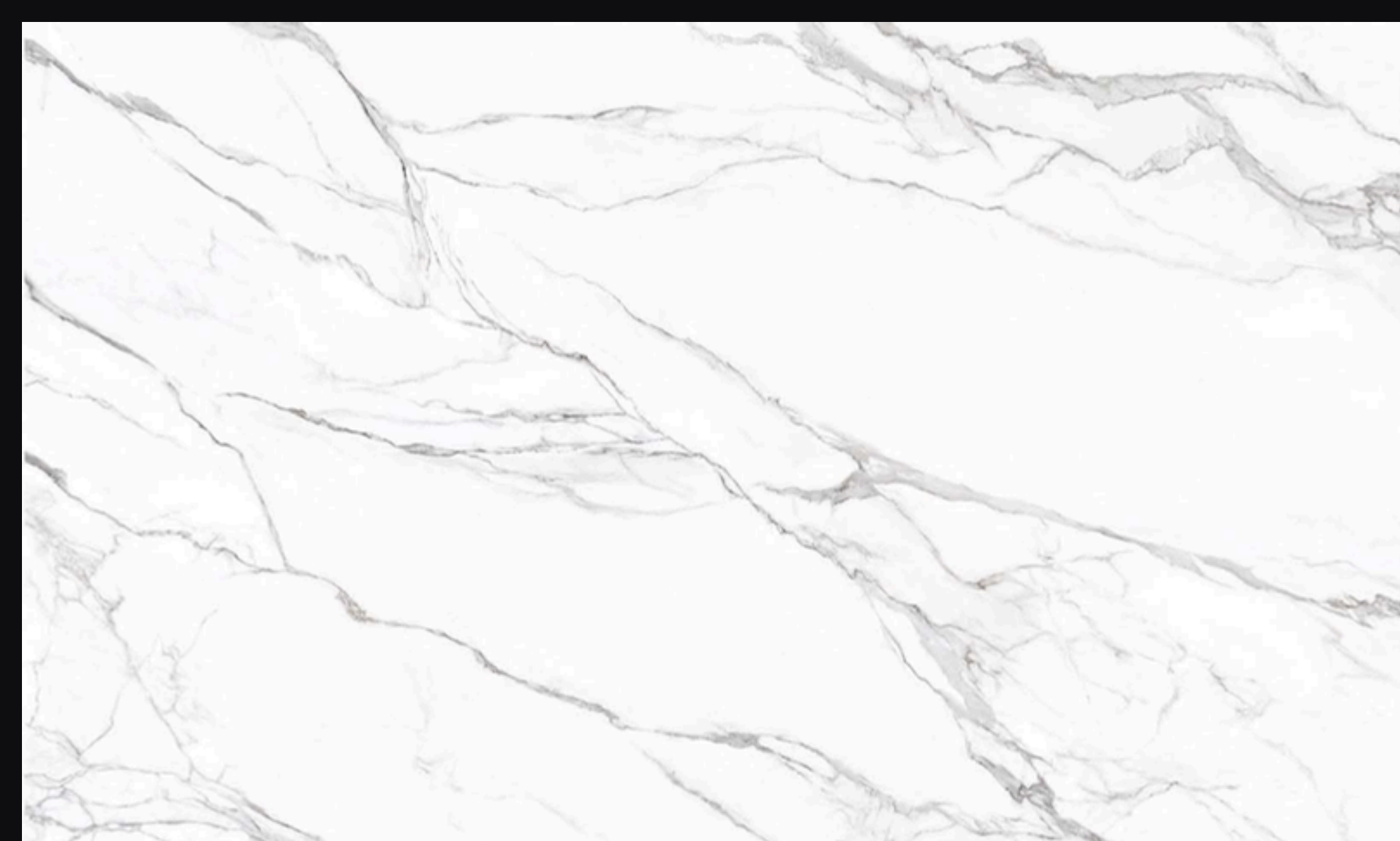

Statuario



Taj Mahal

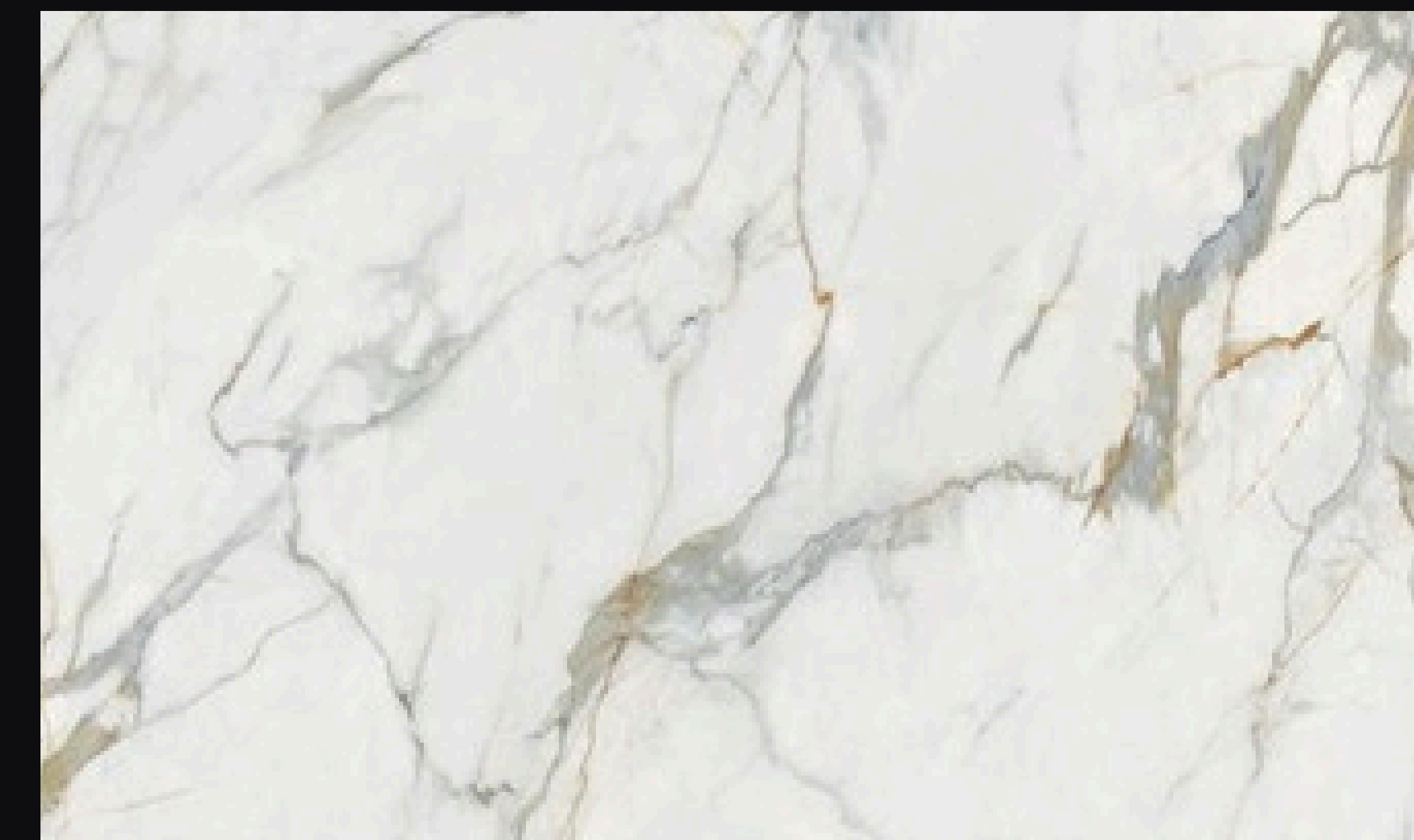

Calacatta Oro

Details:



Statuario



Taj Mahal

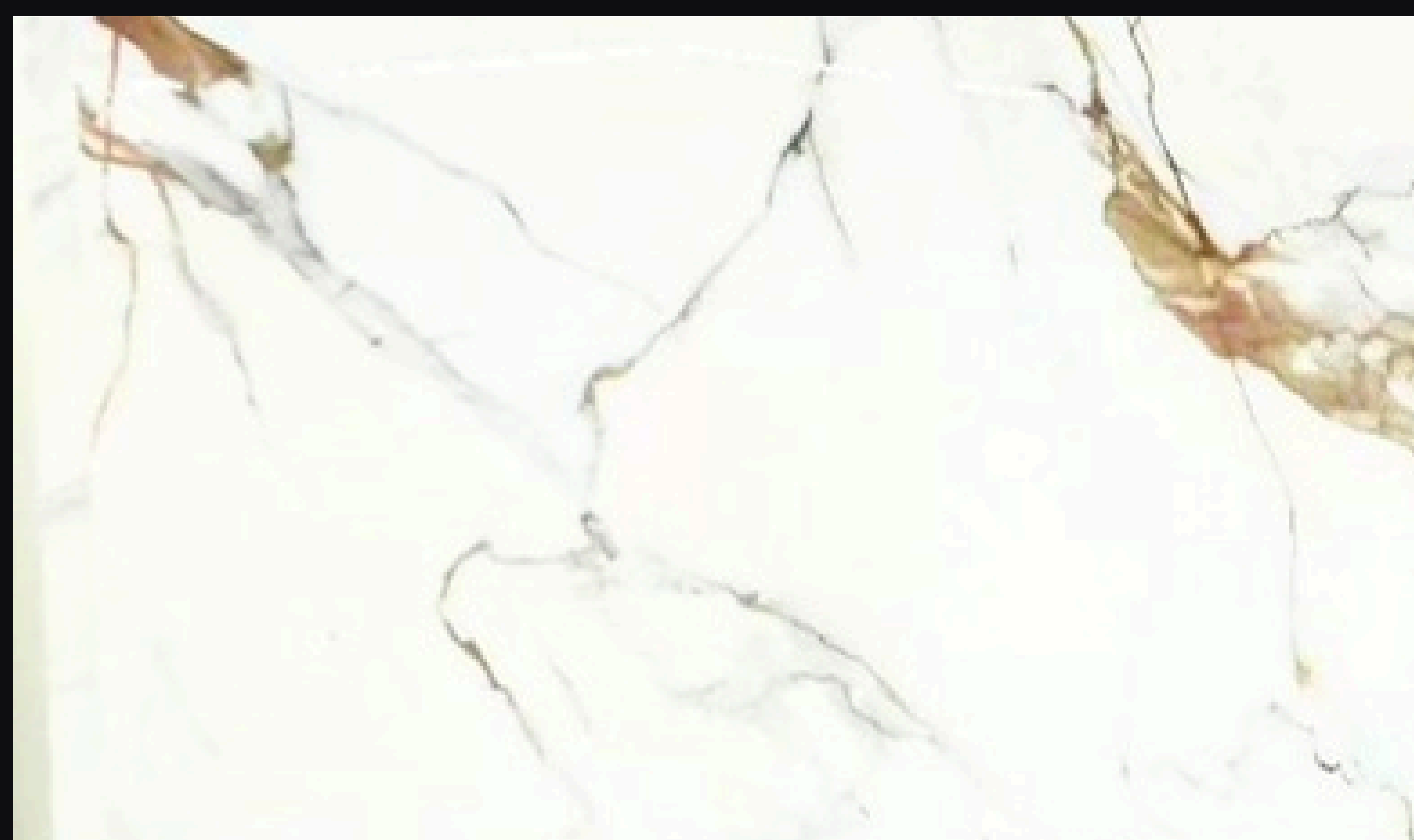

Calacatta Oro

STONEGLASS[®] *Luxury*



PROFILI e BORDI

la varietà è infinita come l'immaginazione.

PROFILES and EDGES

the diversity is an infinite as the imagination:

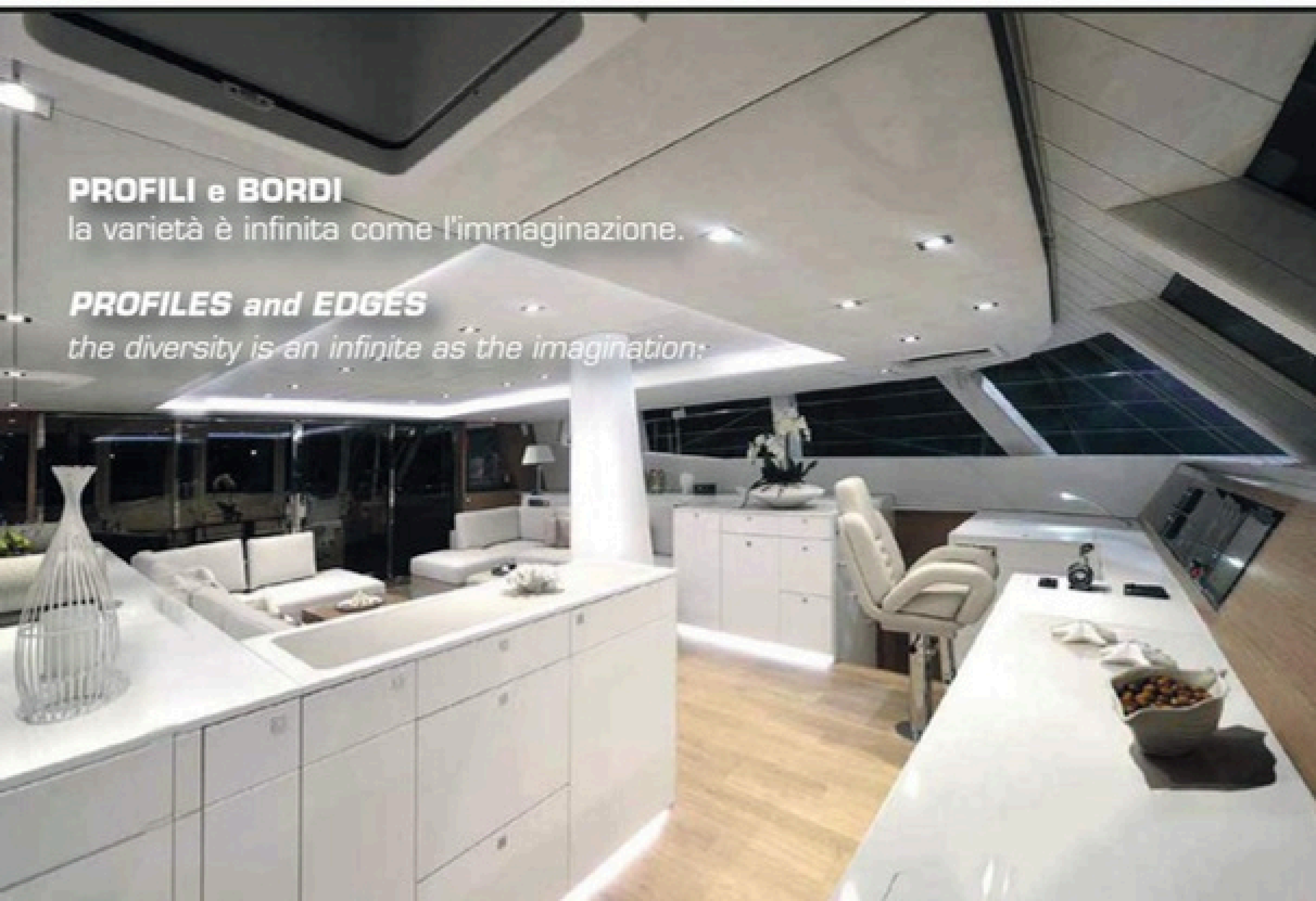

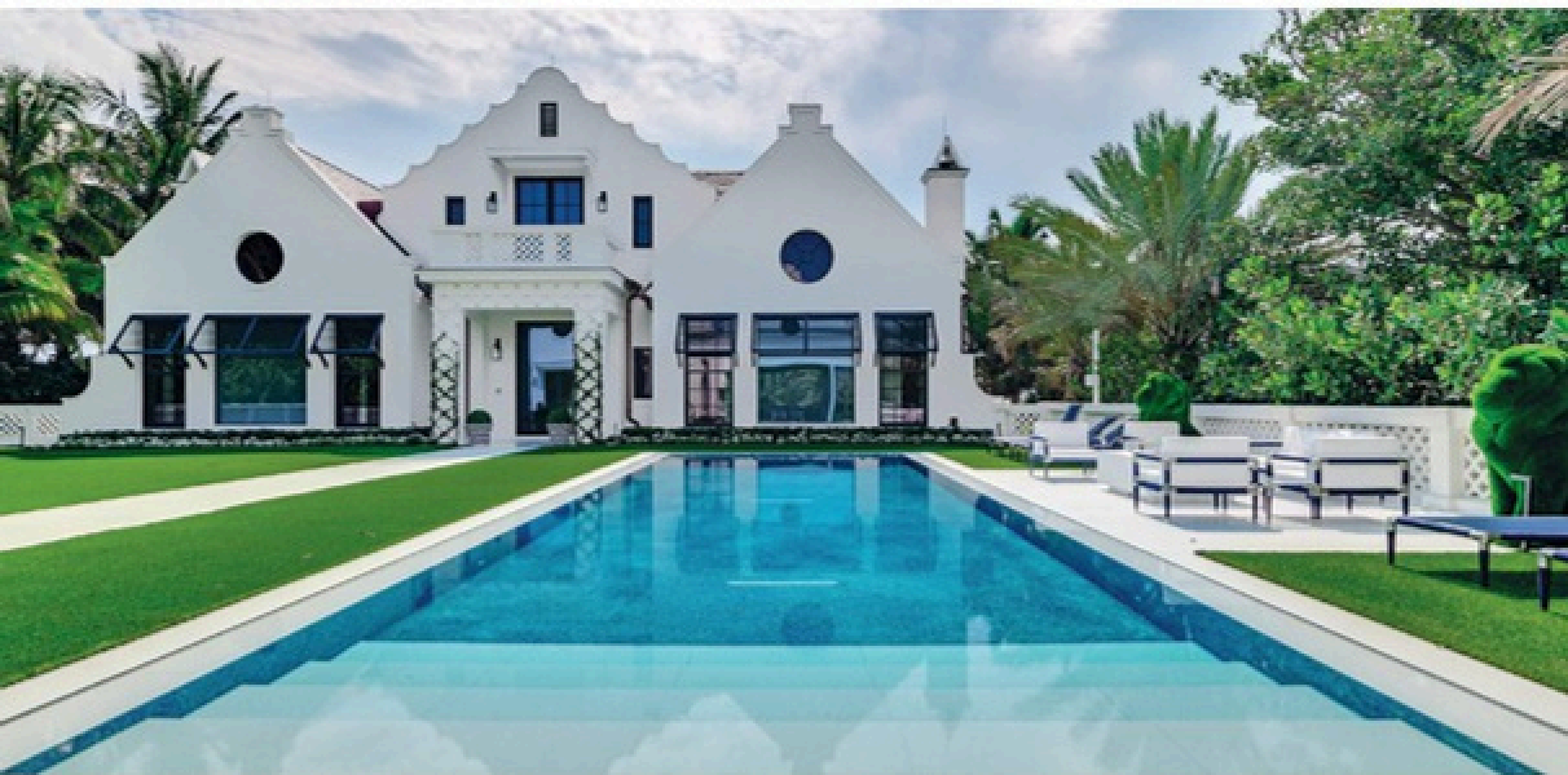

STONEGLASS®

Sensations

STONEGLASS® IN CONTINUA EVOLUZIONE INTRODUCE NUOVE SUPERFICI DI FINITURA, CREANDO LA NUOVA COLLEZIONE SENSATIONS. TUTTE LE NUOVE VARIANTI SONO REALIZZATE UTILIZZANDO COME BASE LE NOSTRE CLASSICHE SUPERFICI CON FINITURA LUCIDO BIANCO E NERO , INTERVENENDO CON TRATTAMENTI MECCANICI SUPERFICIALI.

ECCO LE NUOVE VARIANTI, NATE DALL'INCONTRO TRA FUNZIONALITÀ TECNICA, ESTETICA E L'INCONFONDIBILE MATERIALE STONEGLASS®

STONEGLASS® IN CONTINUOUS EVOLUTION INTRODUCES NEW SURFACE FINISHES, CREATING THE NEW SENSATIONS COLLECTION.

ALL NEW VARIANTS ARE PRODUCED USING OUR CLASSIC WHITE AND BLACK GLOSS FINISHES AS THE BASE, ENHANCED THROUGH SPECIFIC MECHANICAL SURFACE TREATMENTS.

HERE ARE THE NEW VARIANTS, BORN FROM THE COMBINATION OF TECHNICAL FUNCTIONALITY, AESTHETICS, AND THE UNMISTAKABLE STONEGLASS® MATERIAL.

WHITE FINISHES

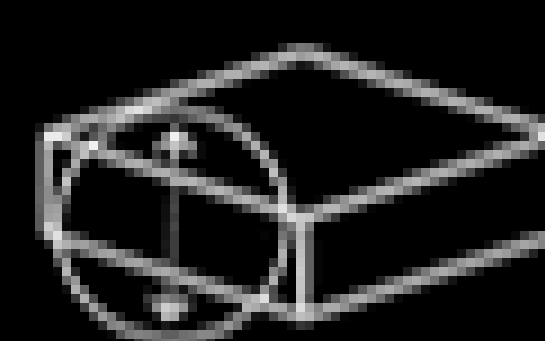

THICKNESS
4-6-10-12-
18-30 mm

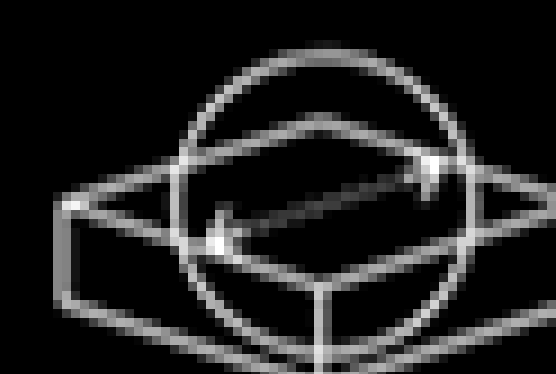

MAX WIDTH
& LENGHT
3060x1640
mm

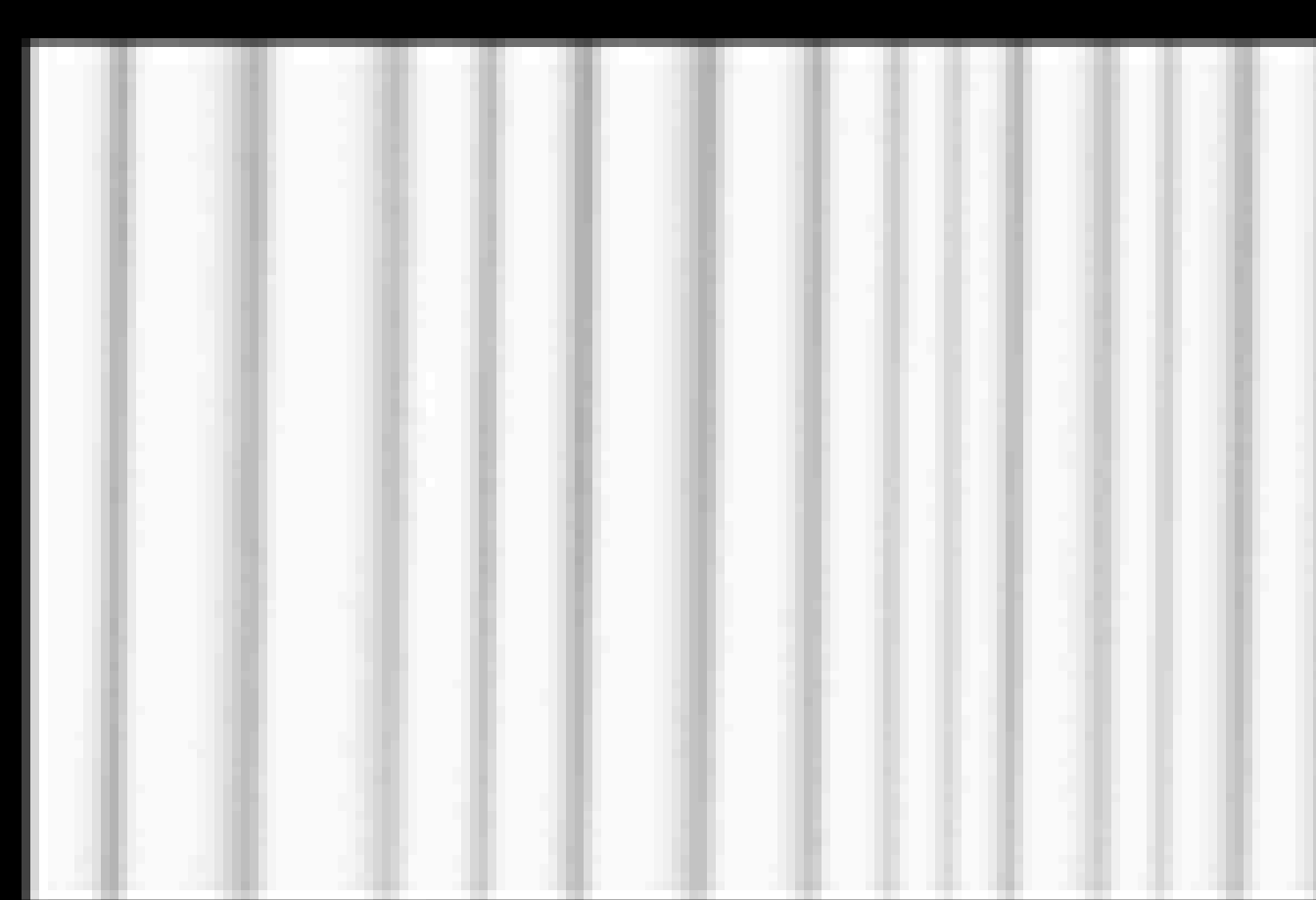

Bambù

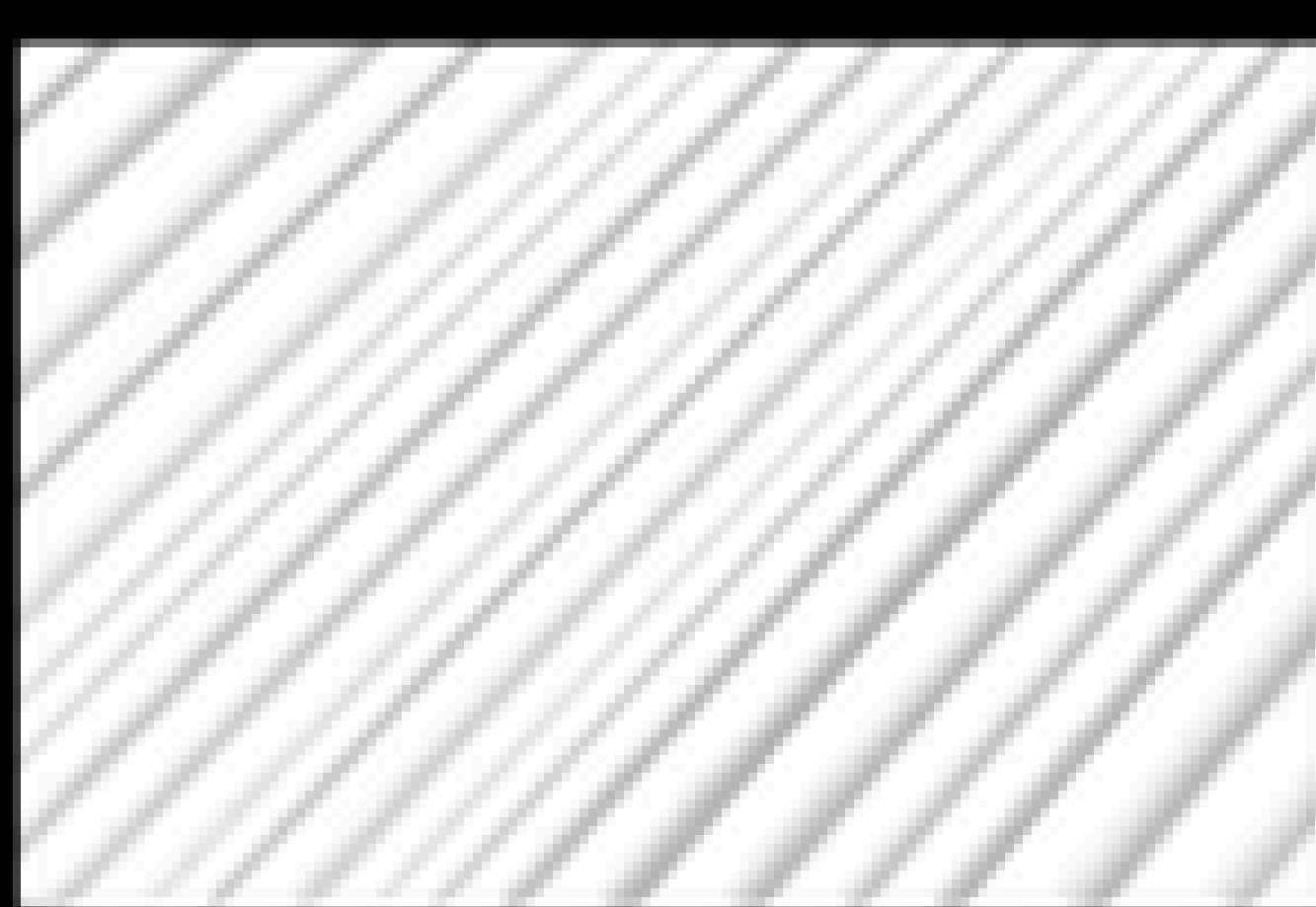

Alpi

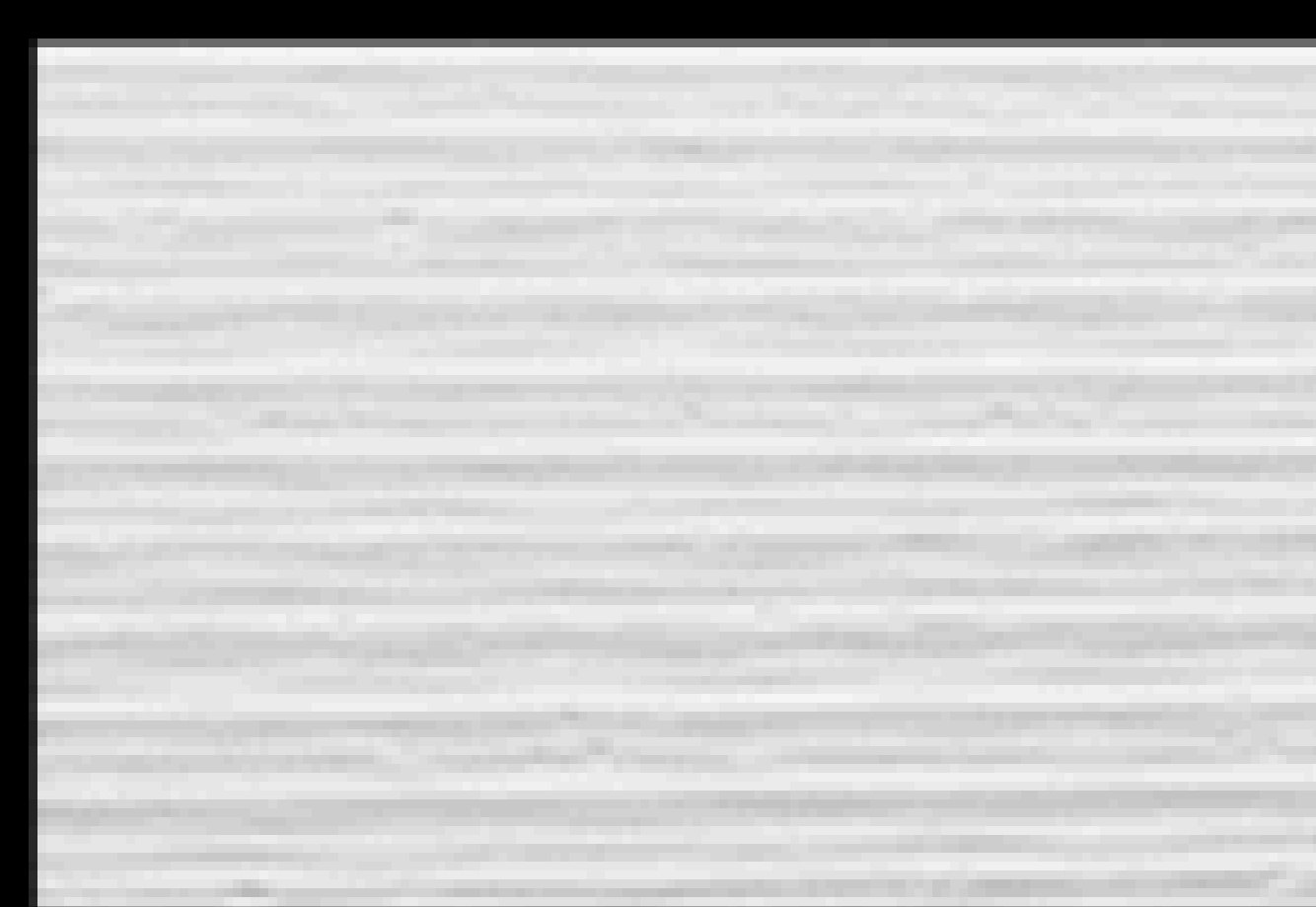

Corteccia Plus

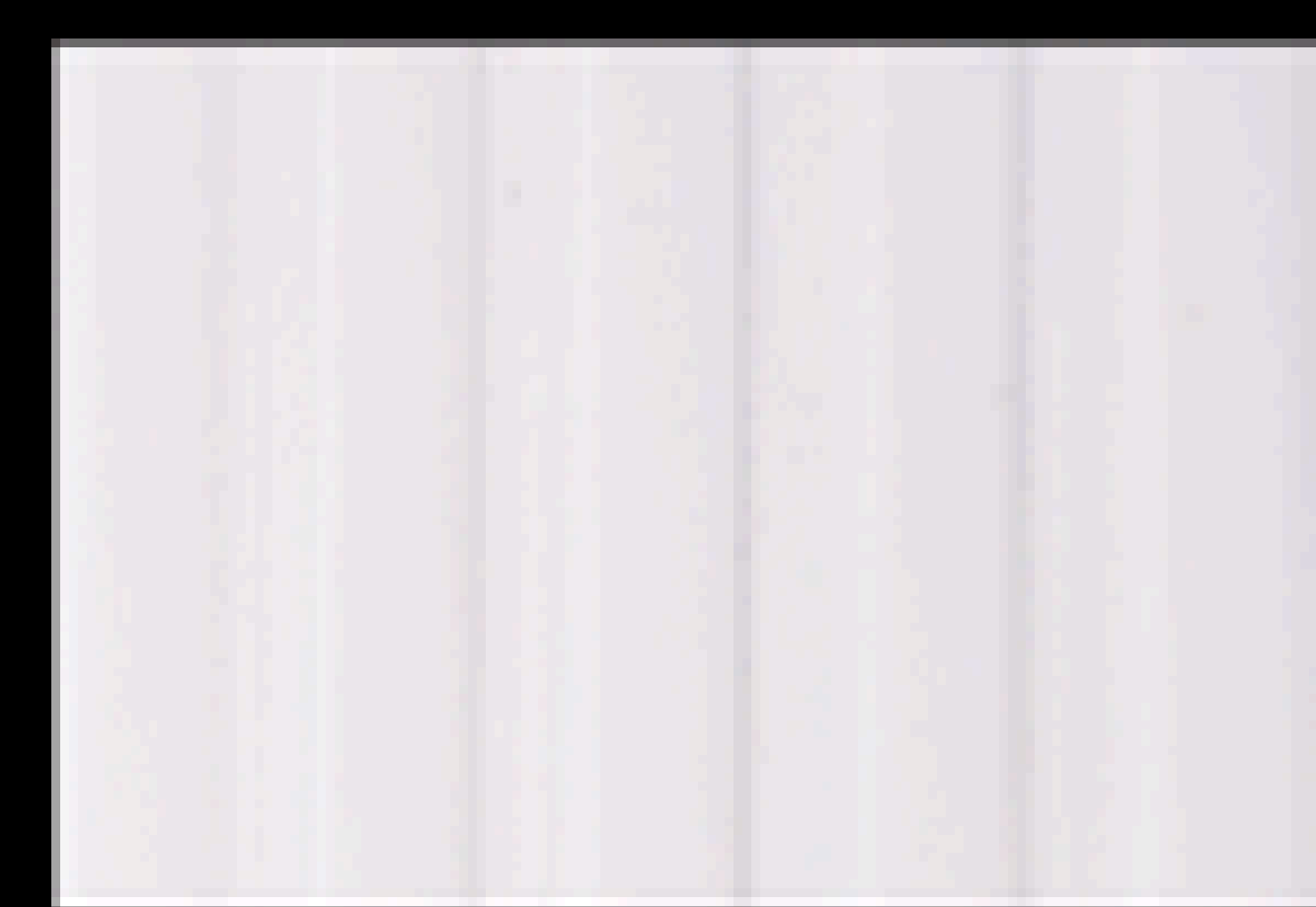

Rigato 5+5



Breeze

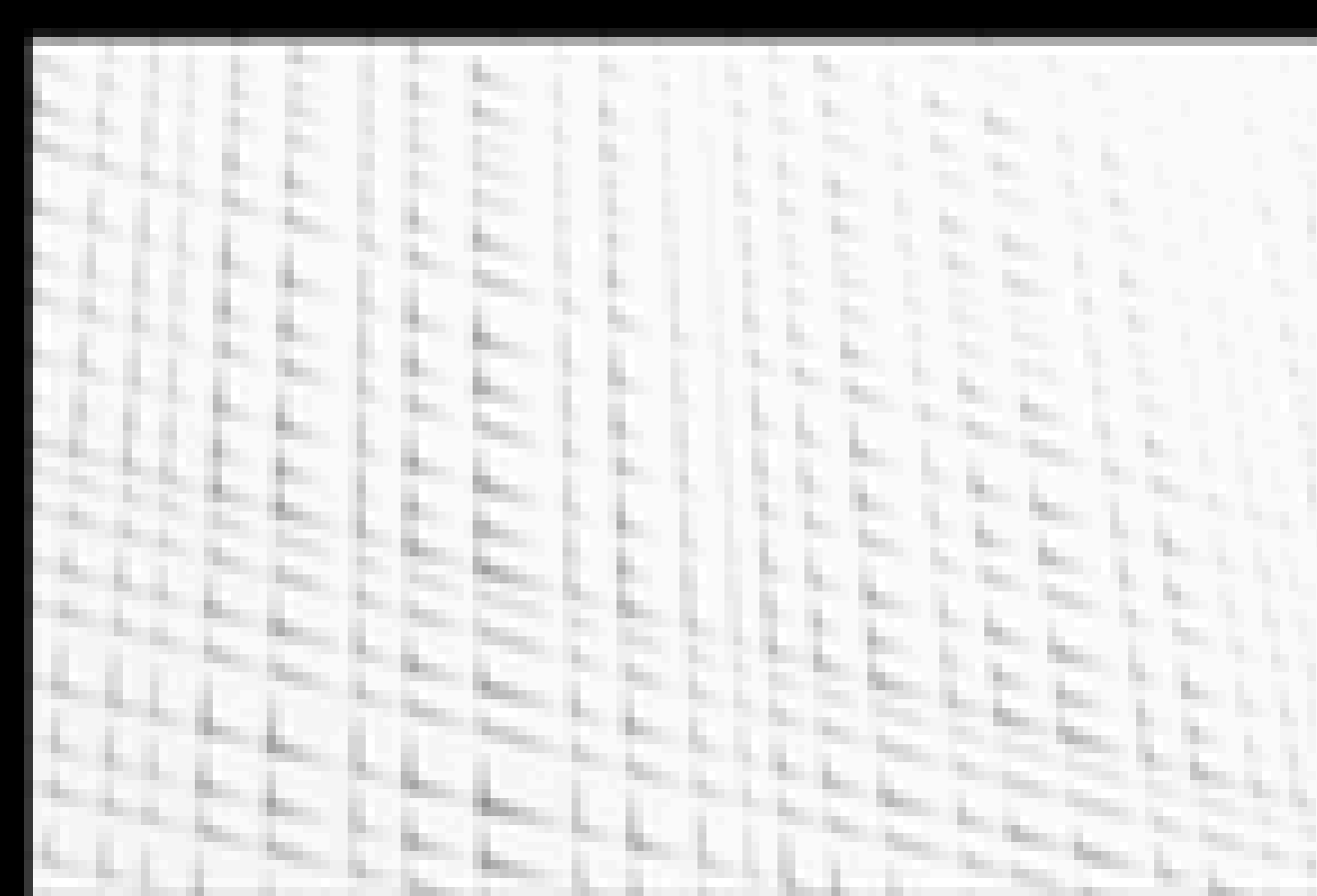

Cityroad

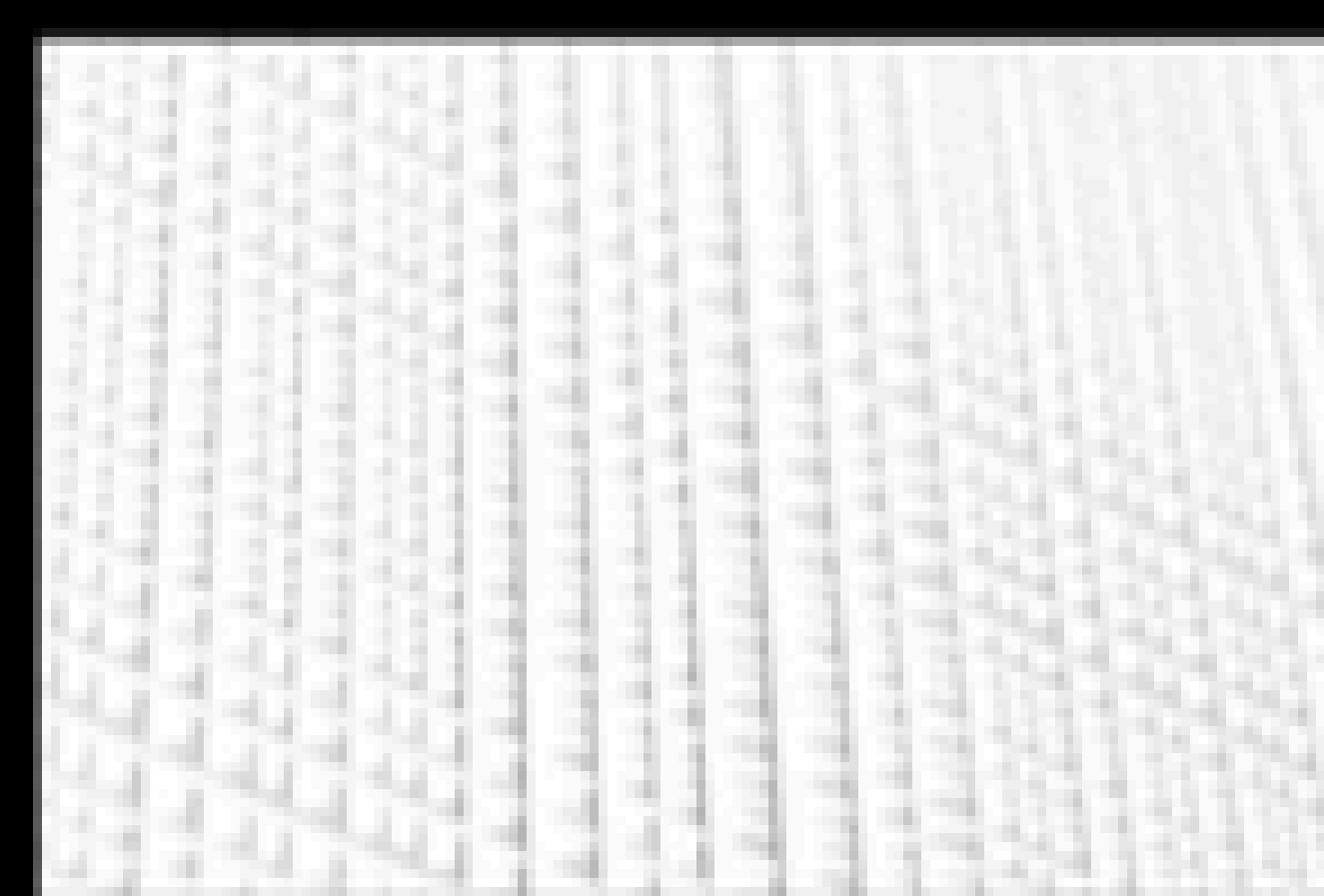

Manhattan

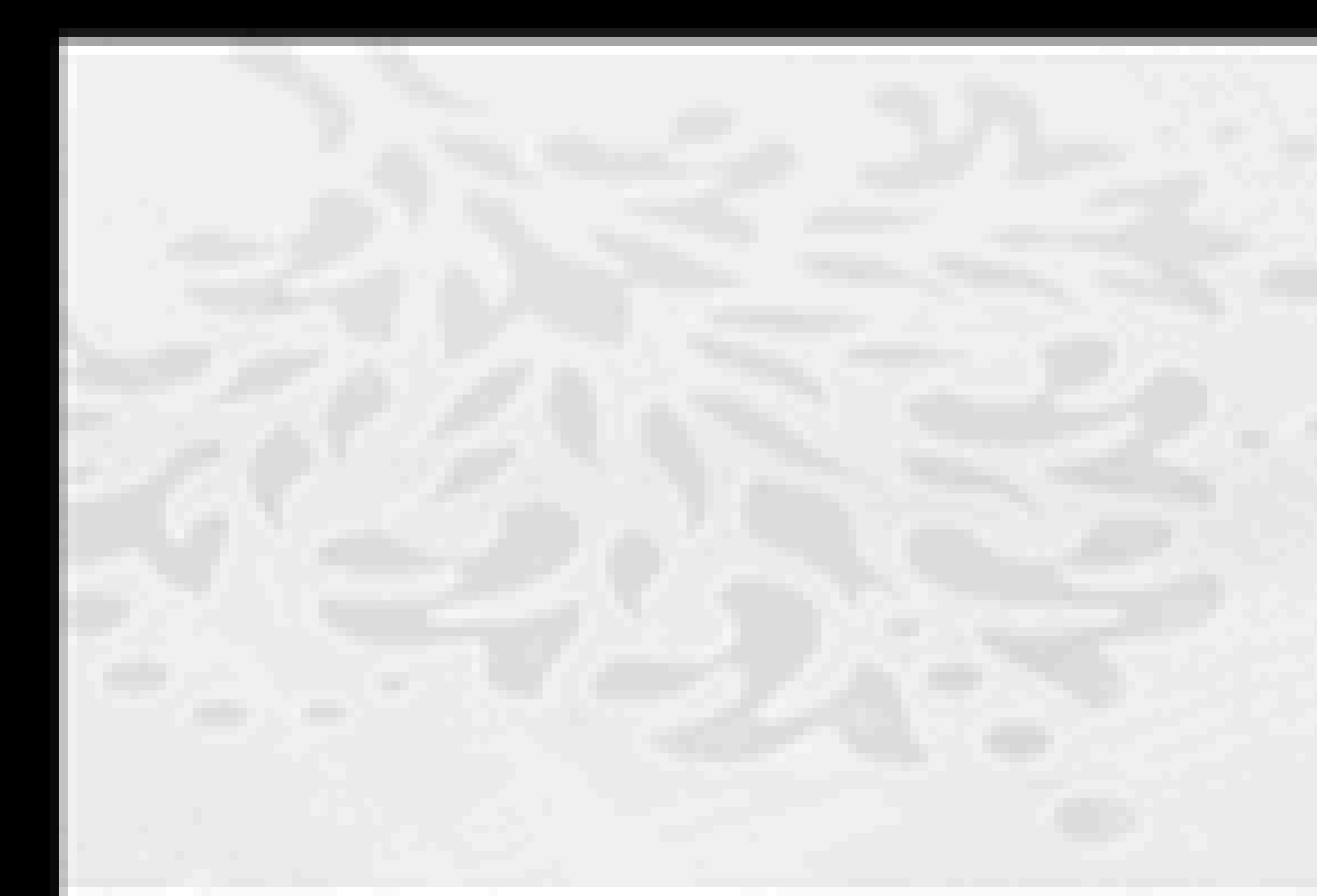

Laser Labirint



Tranché



Matt

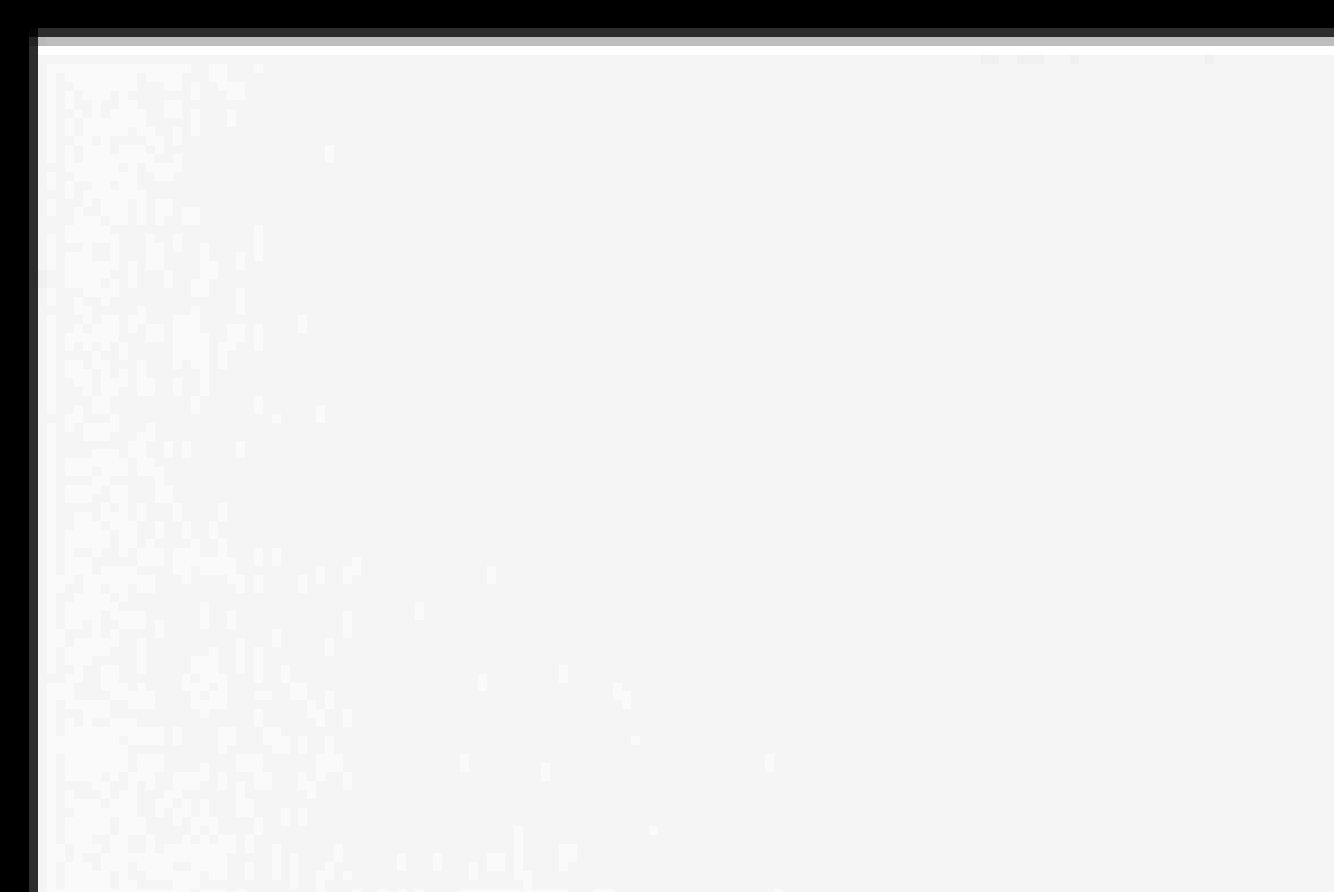

Polished



Antiscivolo

BLACK FINISHES

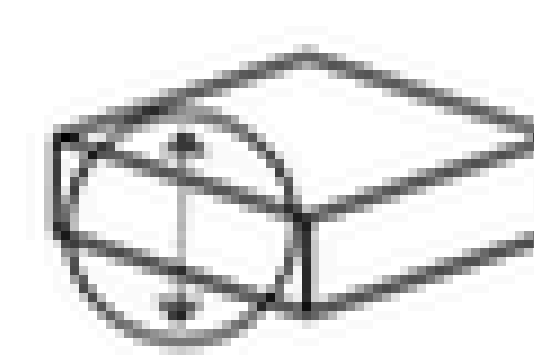

THICKNESS
18 mm

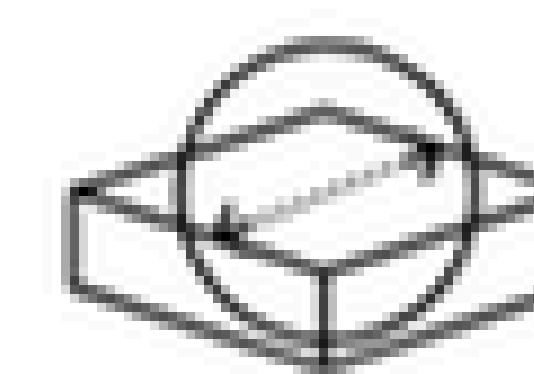

MAX WIDTH
& LENGTH
2560x2134
mm

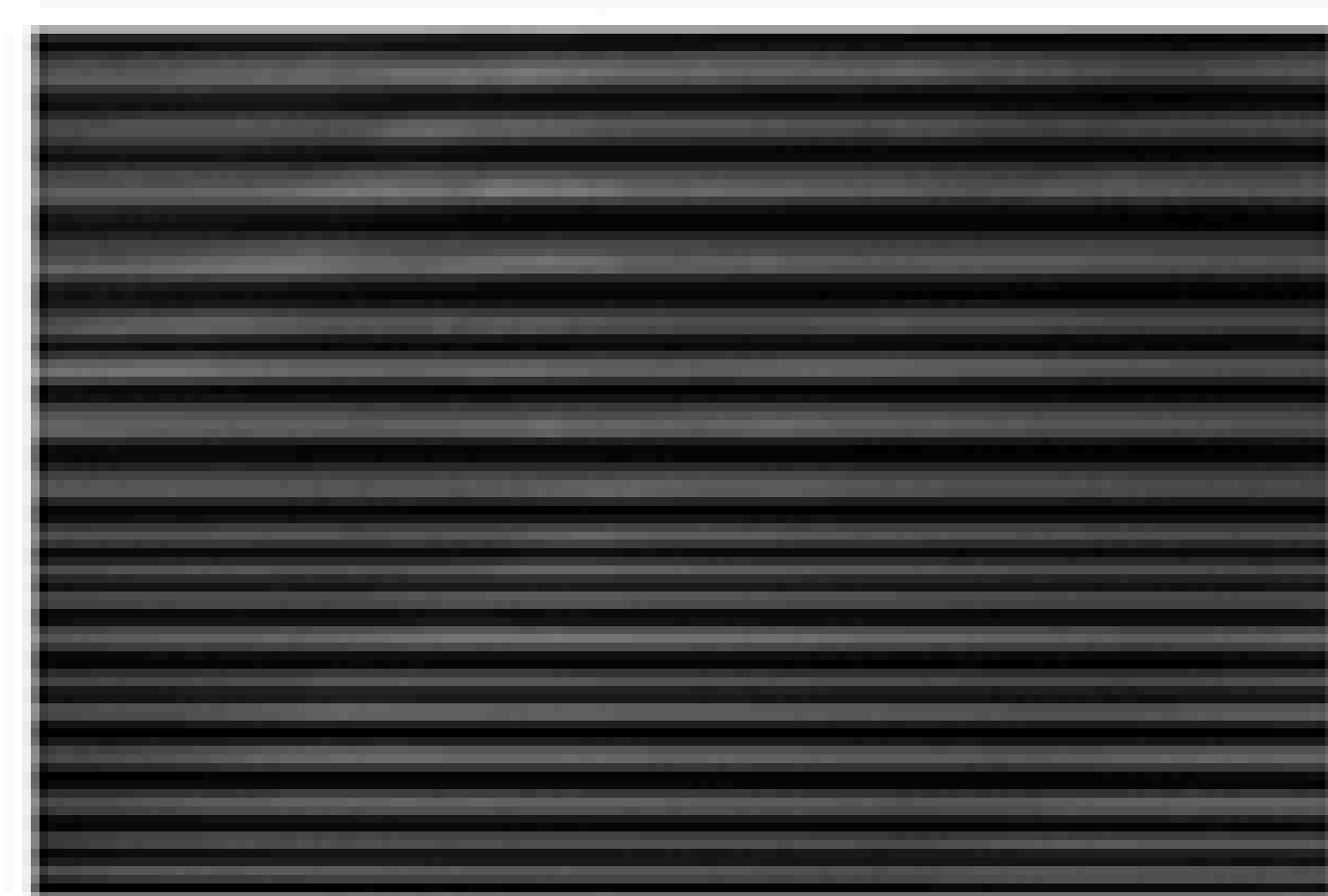

Bambù

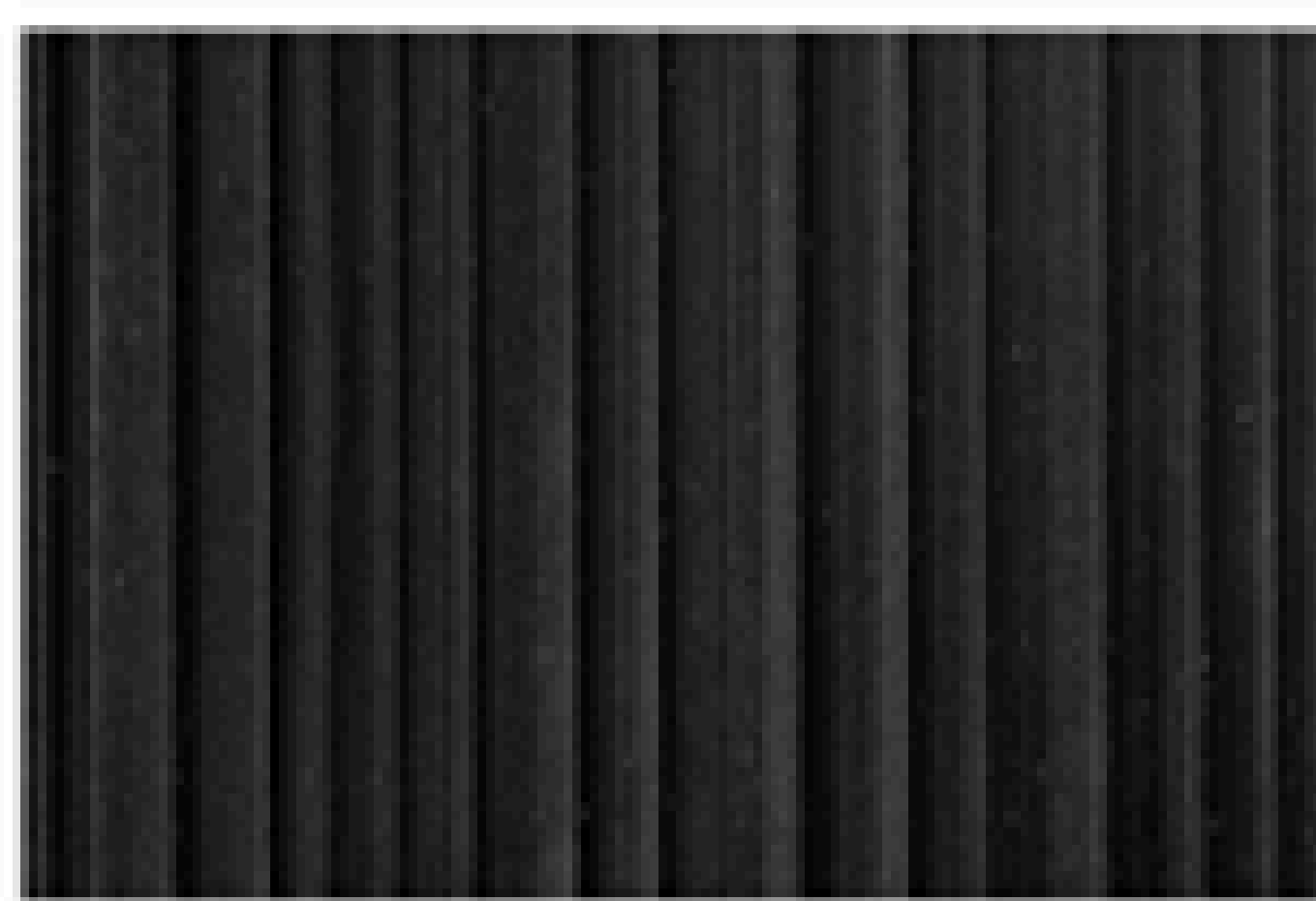

Alpi

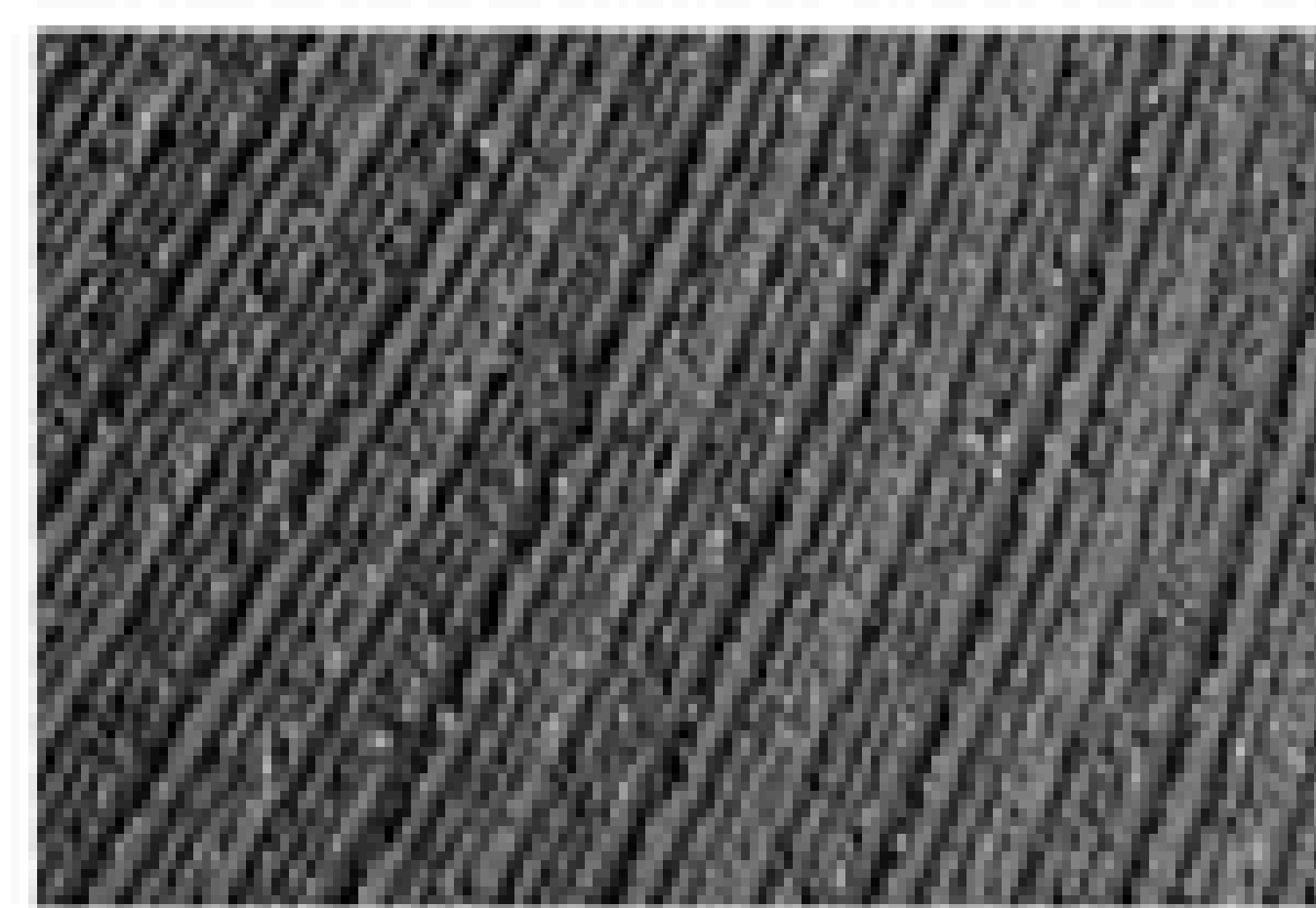

Rainbow

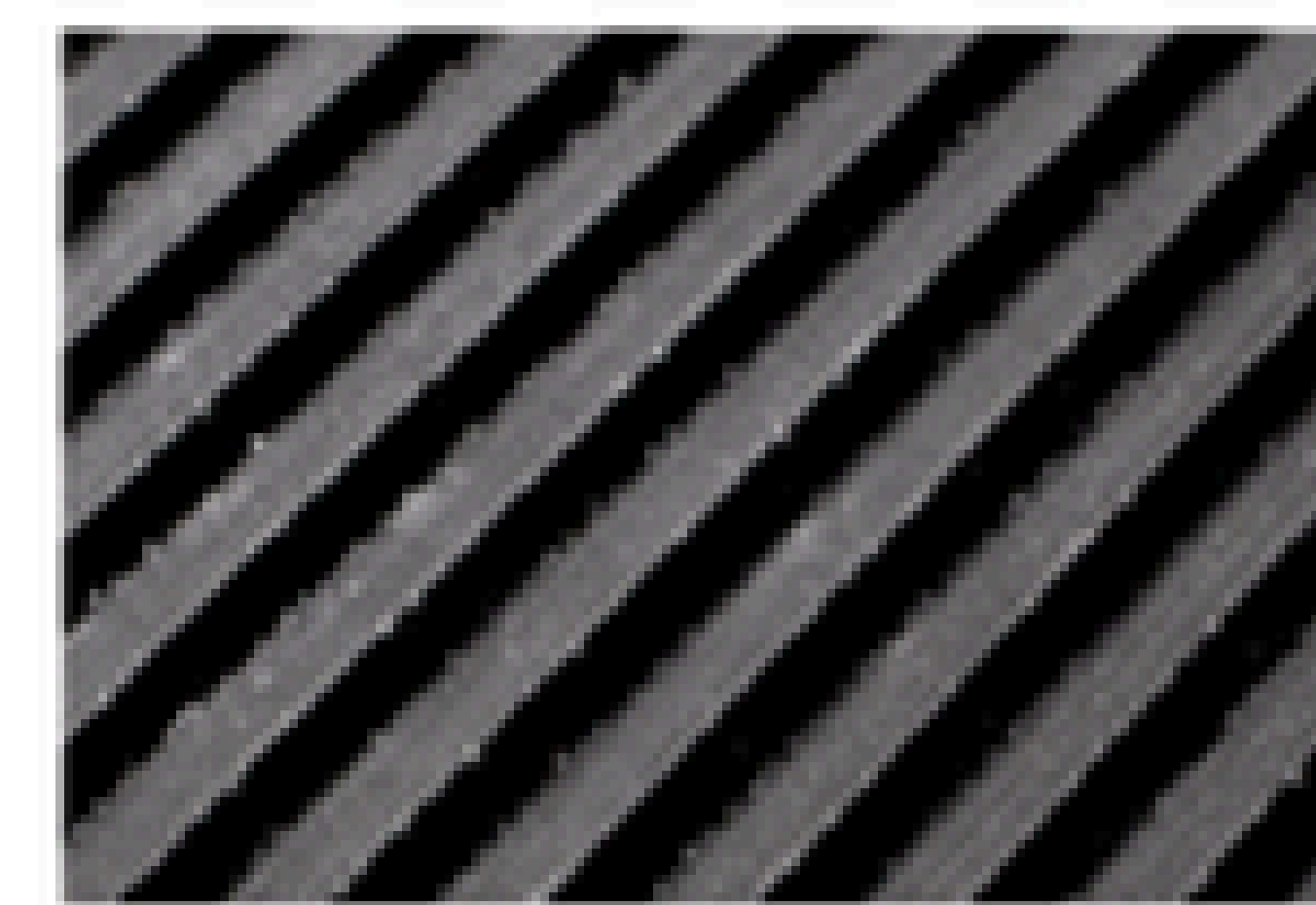

Rigato 5+5

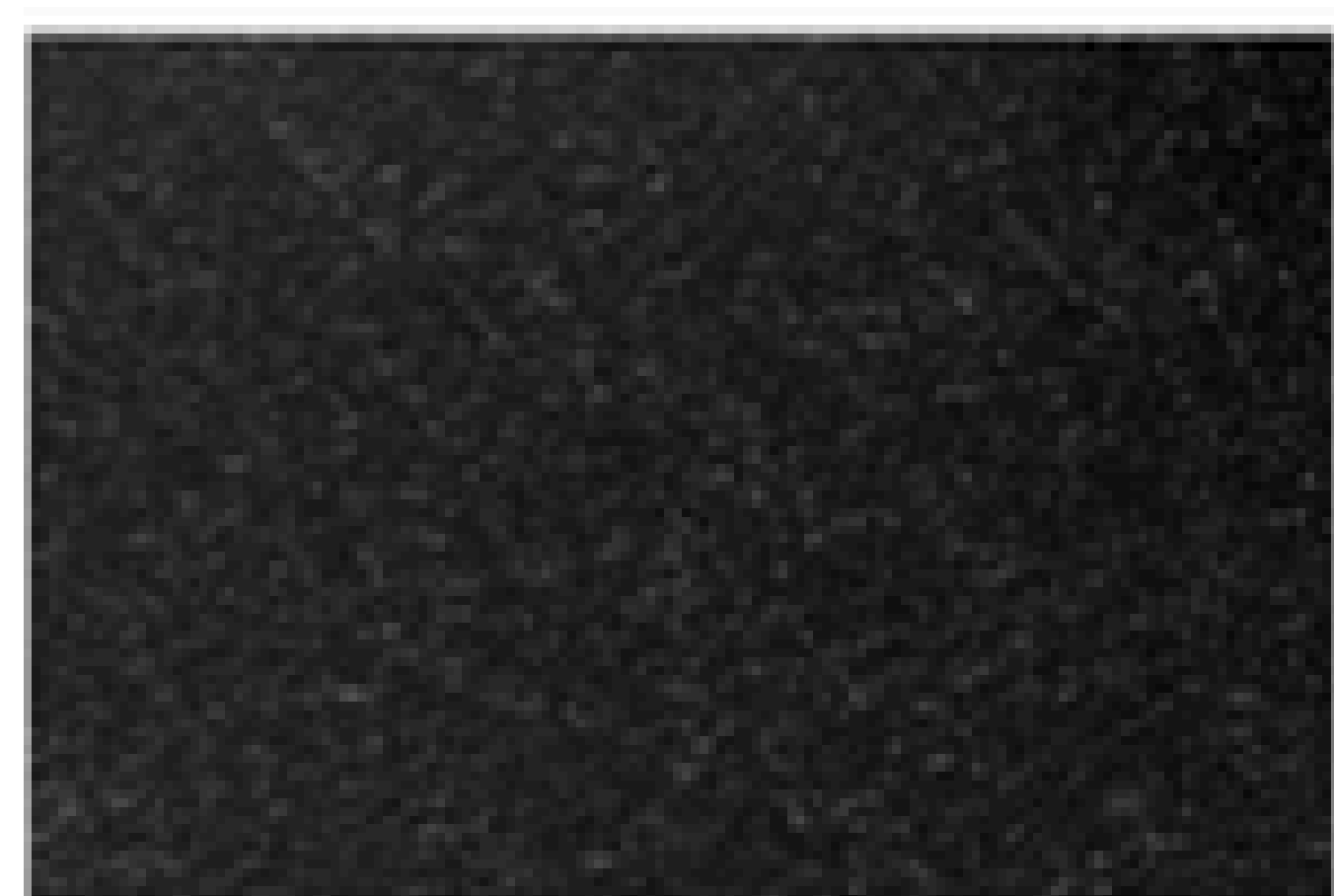

Wood

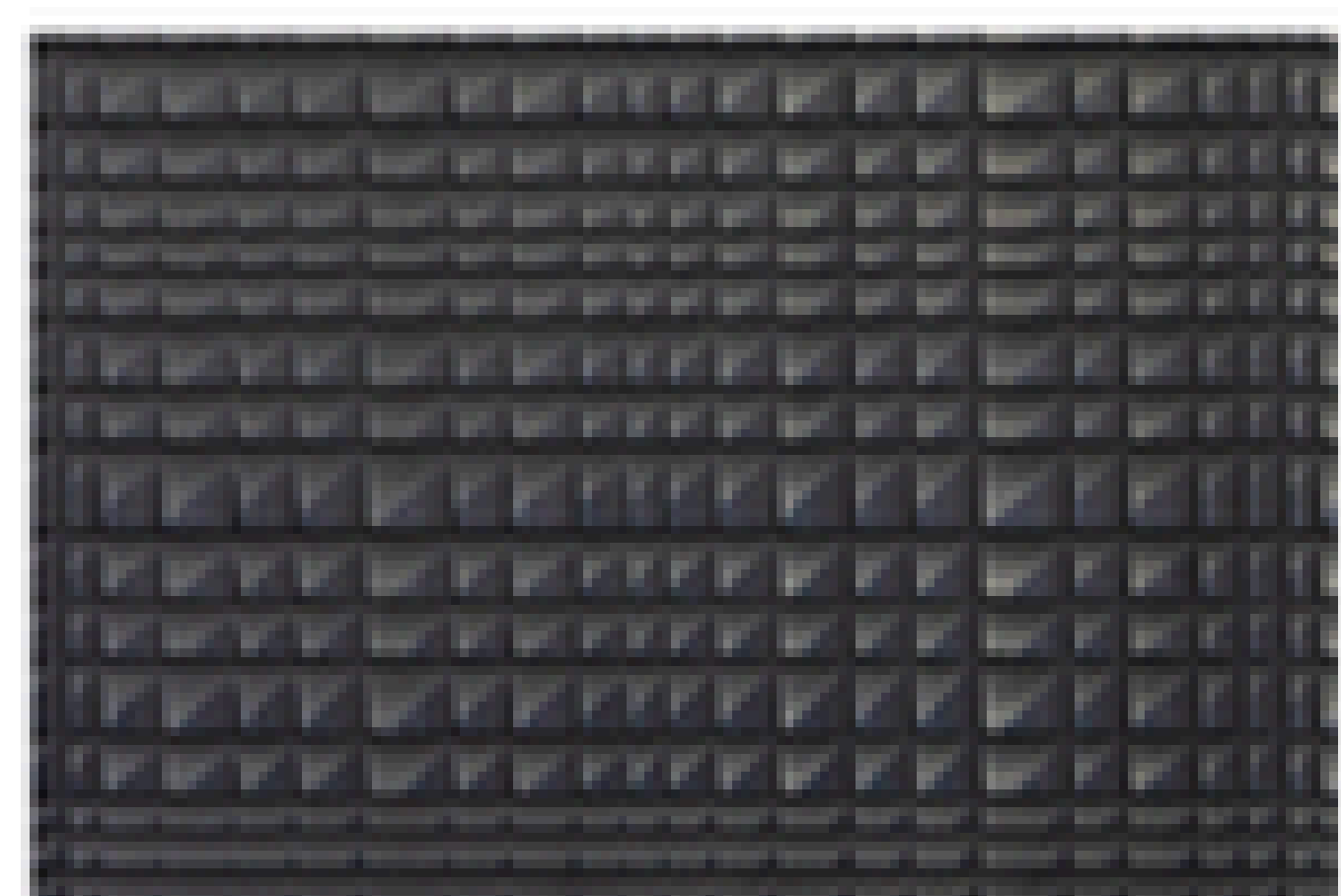

Cityroad

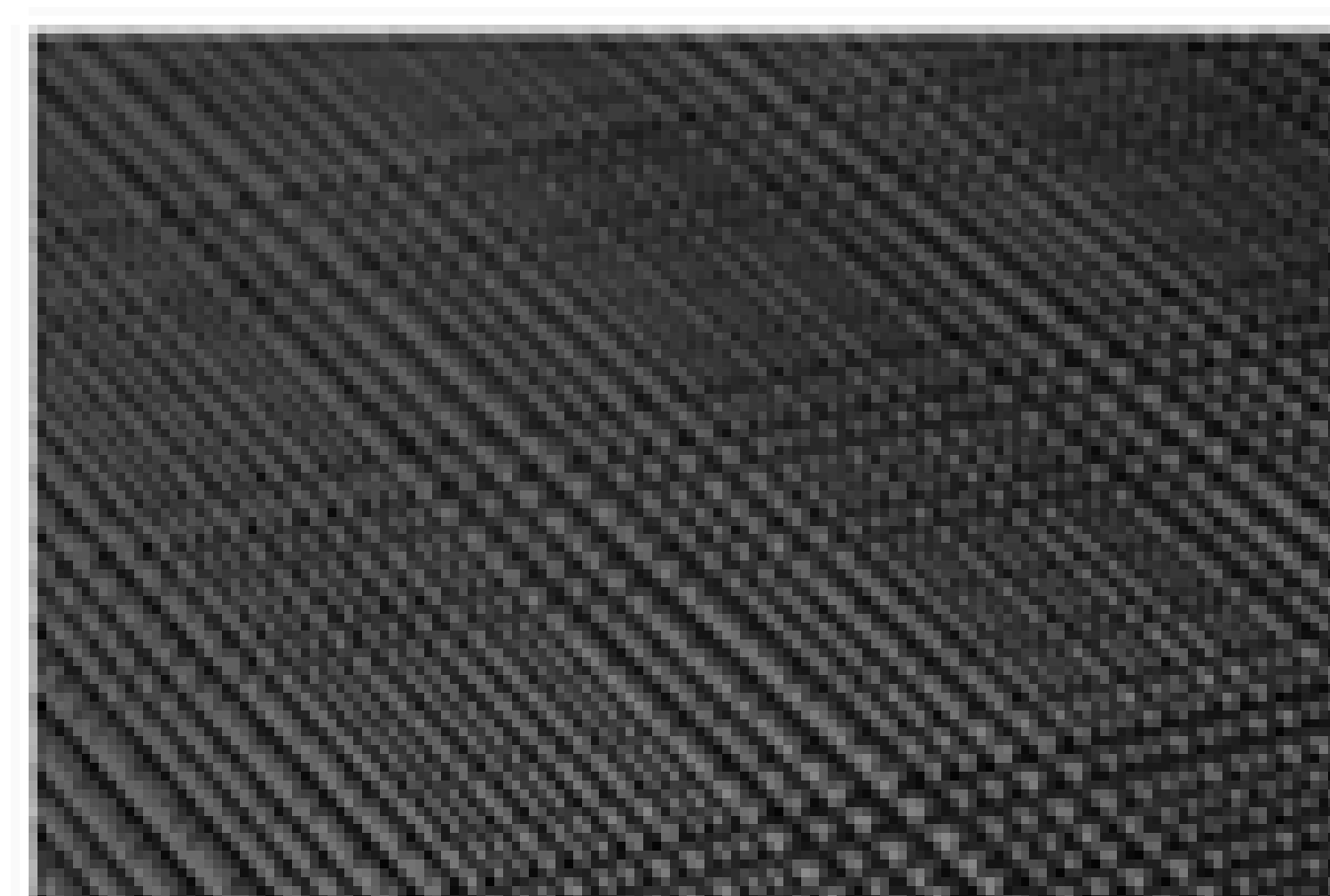

Manhattan

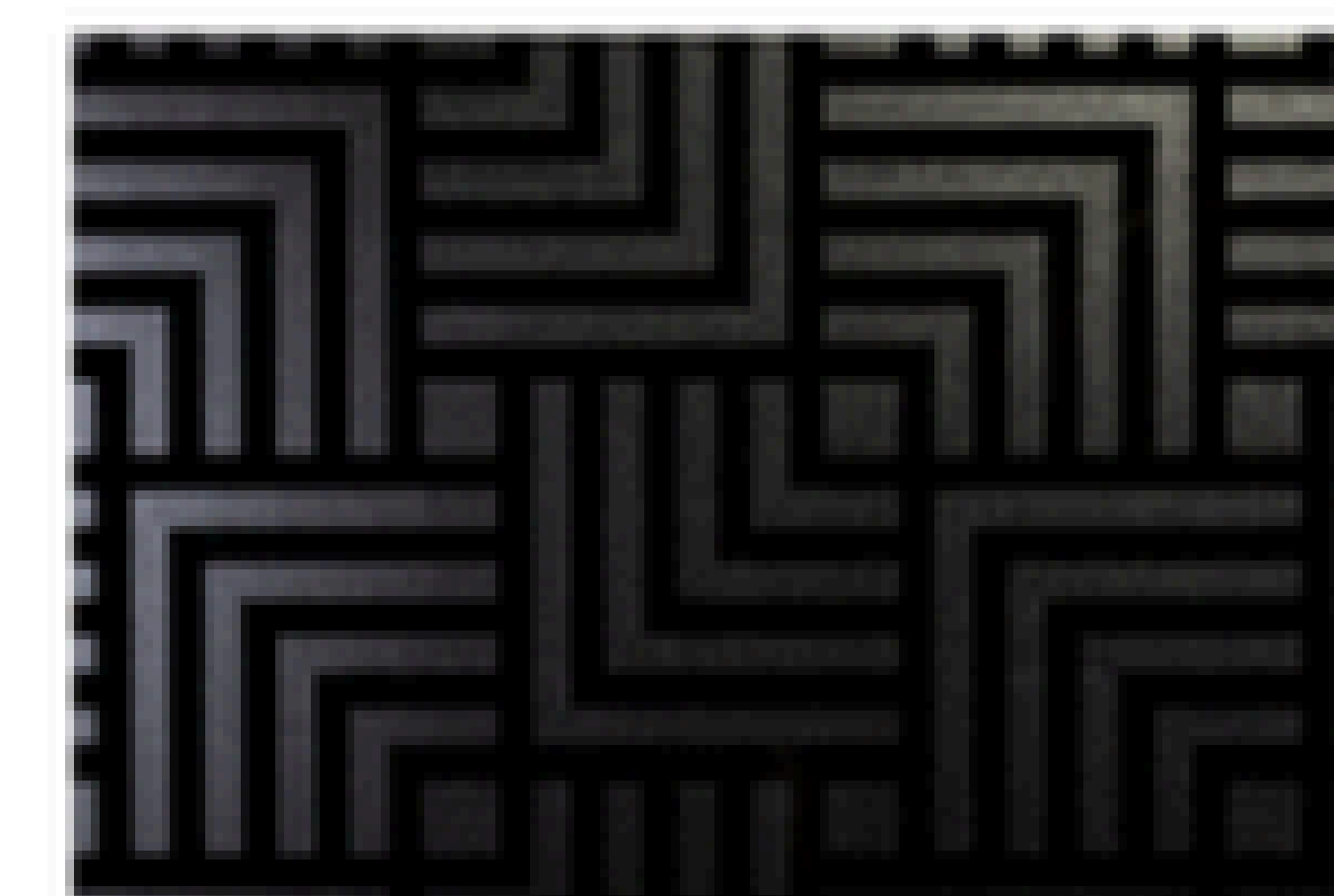

Laser Basket

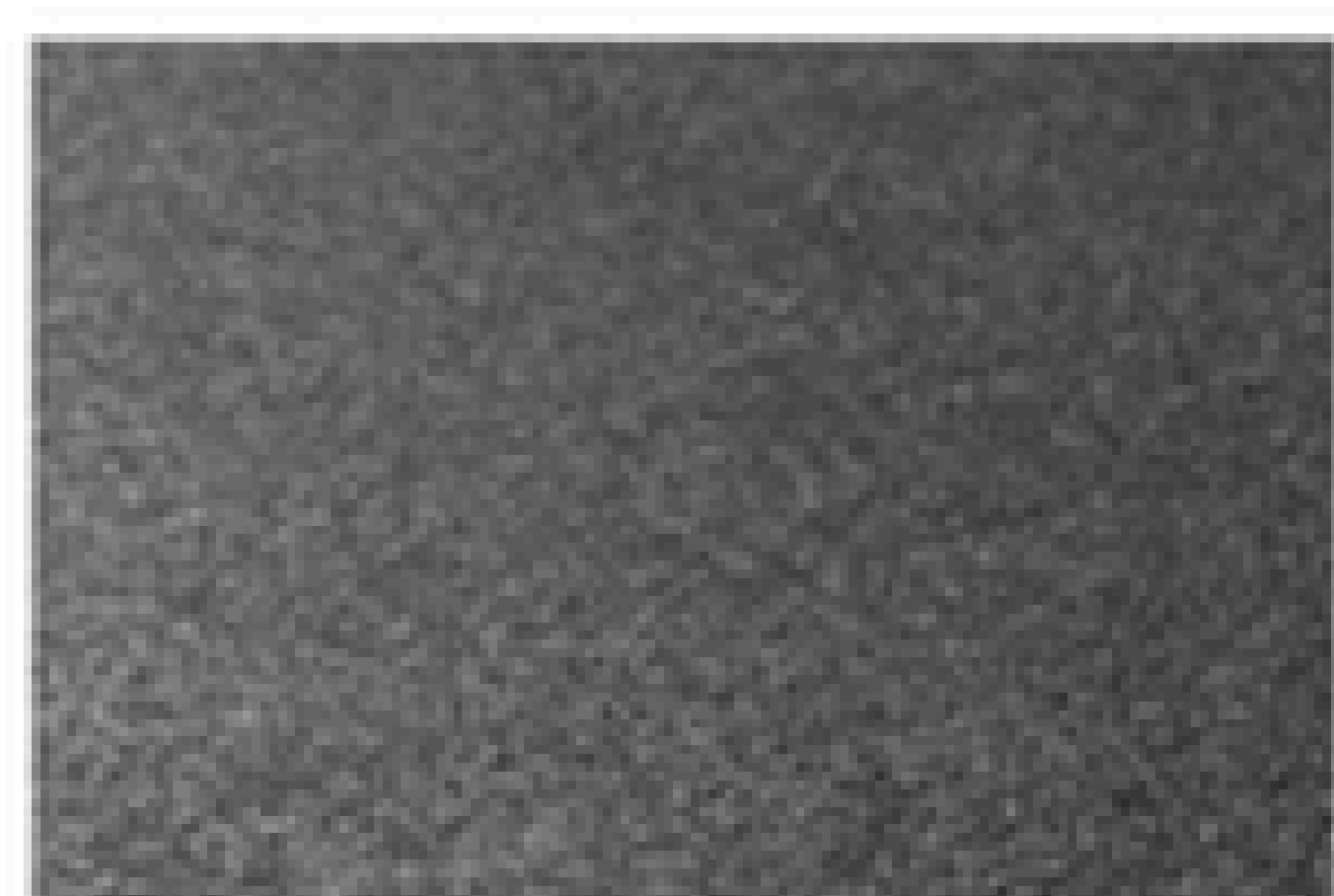

Wood Grey

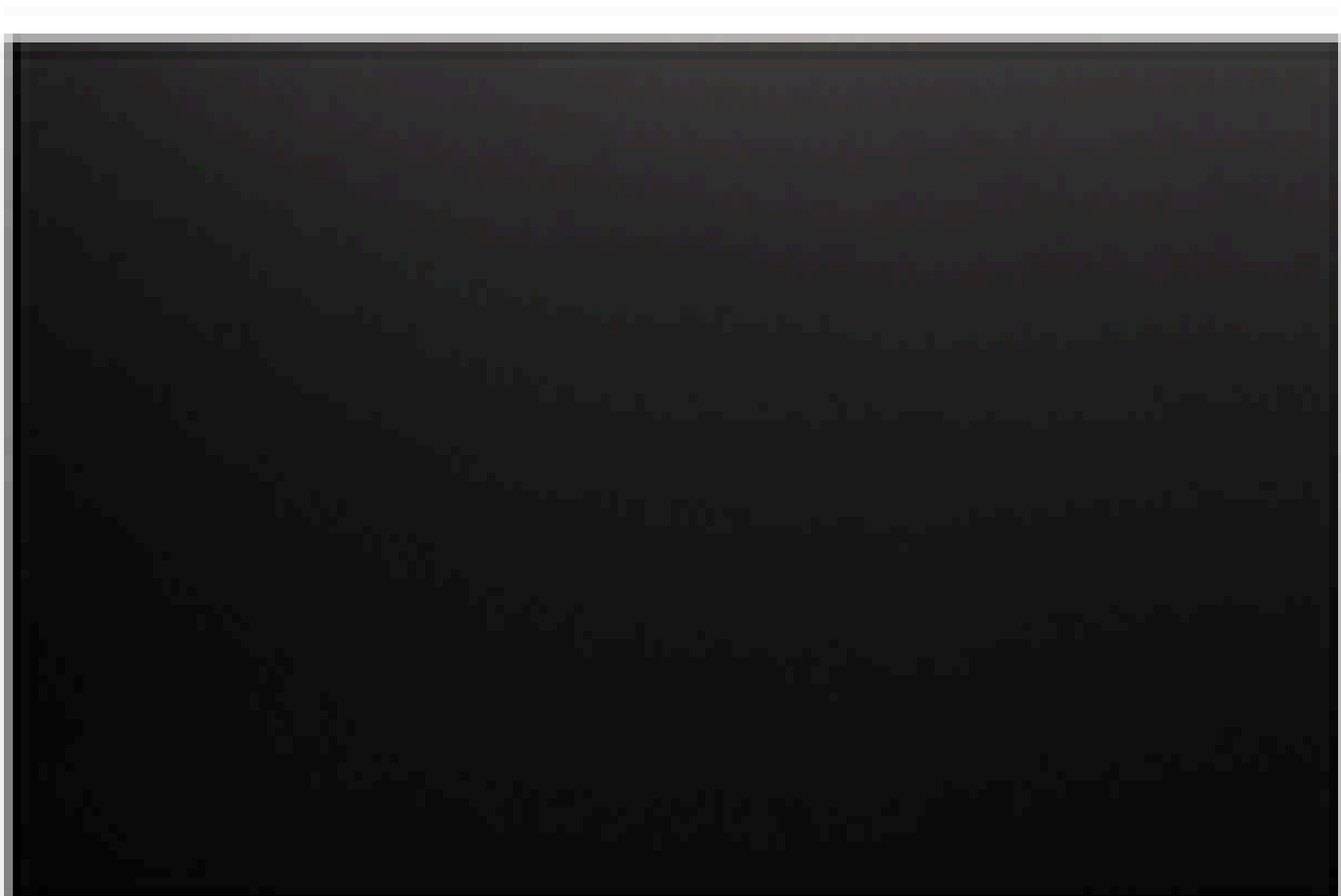

Matt

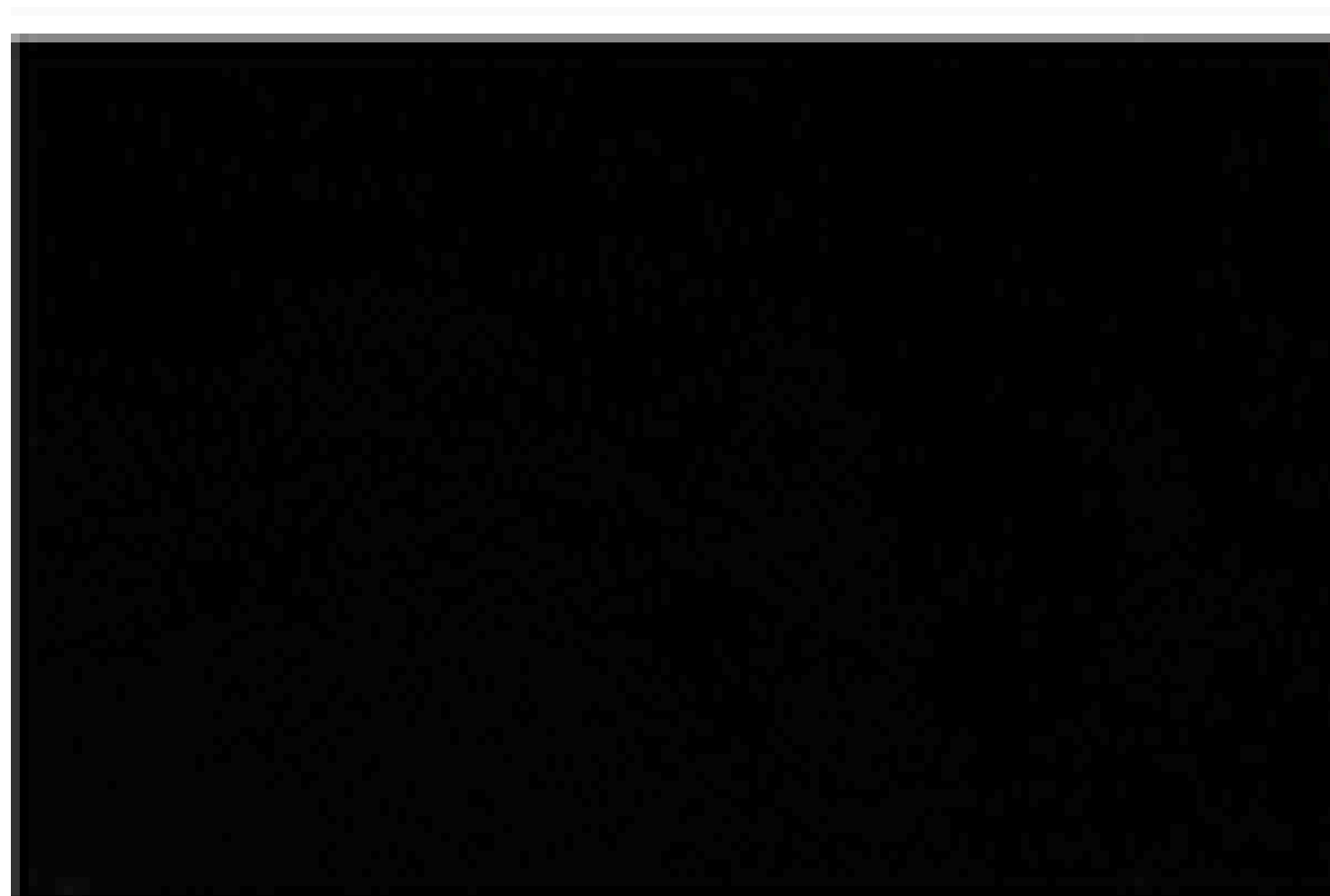

Polished

VENTO, CALORE E ACQUA MODELLANO E TRASFORMANO LA MATERIA. LA FORZA DELLA NATURA SAPIENTEMENTE GUIDATA DALLA MANO DELL'UOMO MODELLA E TRASFORMA LO STONEGLASS®. LA SEMPLICITÀ, LA RESISTENZA E LA SOLIDITÀ DELLO STONEGLASS® DIVENTANO PURA EMOZIONE IN QUESTA NUOVA COLLEZIONE DI TEXTURE INNOVATIVE COMPLETAMENTE "MADE IN ITALY" NATE PER TRASFORMARE UN PAVIMENTO O UN RIVESTIMENTO IN UNA PICCOLA E PREZIOSA OPERA D'ARTE.

THE ART OF CREATING EMOTIONS

WIND, HEAT AND WATER SHAPE AND TRANSFORM RAW MATERIAL. THE FORCE OF NATURE WISELY GUIDED BY THE HAND OF MAN SHAPES AND TRANSFORMS THE STONEGLASS®. THE SIMPLICITY, STRENGTH AND SOLIDITY OF THE STONEGLASS® BECOME PURE EMOTION IN THIS NEW COLLECTION OF INNOVATIVE TEXTURES COMPLETELY "MADE IN ITALY" BORN TO TRANSFORM A FLOOR OR A COVERING IN A SMALL AND PRECIOUS ARTWORK.

STONEGLASS® Sensations of The New World
Photo collection: slabs, details, emotionals





-LASER-



-RIGATO 5#5-

-MATT-

-RAINBOW-



-LASER-

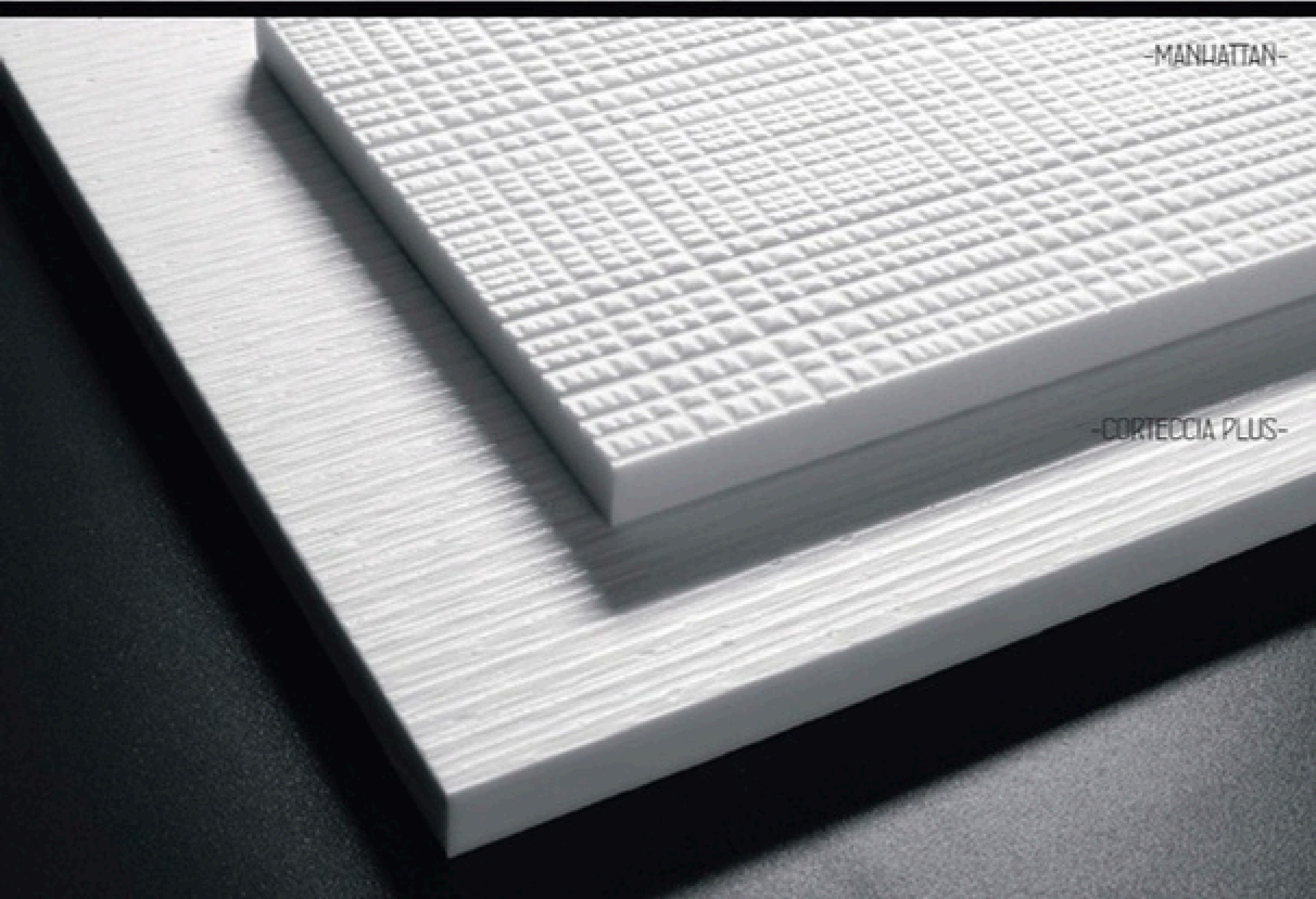

-MANHATTAN-

-CORTECCIA PLUS-

"QUANDO TROVERO' UN COLORE PIU' SCURO DEL
NERO, LO INDOSSERO'. MA FINO A QUEL MOMENTO,
MI VESTIRO' DI NERO".

*"WHEN I FIND A COLOUR DARKER THAN BLACK, I'LL WEAR IT. BUT
UNTIL THEN, I'M WEARING BLACK".*

(Coco Chanel)





-MANIATTAN-

-ALPI-

-BAMBU-



-CITYROAD-

-RIGATO 5+5-



-WOOD-



-MANHATTAN-

"L'ARCHITETTURA È UNA SCULTURA ABITATA"

"THE ARCHITECTURE IS AN INHABITED SCULPTURE"

-TRANCHE'-

-MATT-

-MANLIATTAN-



-ALPI-



-CORTECCIA PLUS-





STONEGLASS®

Tiles

-BAMBU'-



"LA SEMPLICITA' E' LA NOTA
FONDAMENTALE DI OGNI VERA ELEGANZA."

"SIMPLICITY IS THE KEYNOTE OF ALL TRUE ELEGANCE."

(Coco Chanel)

-SIRE 20°-





-BAMBU-

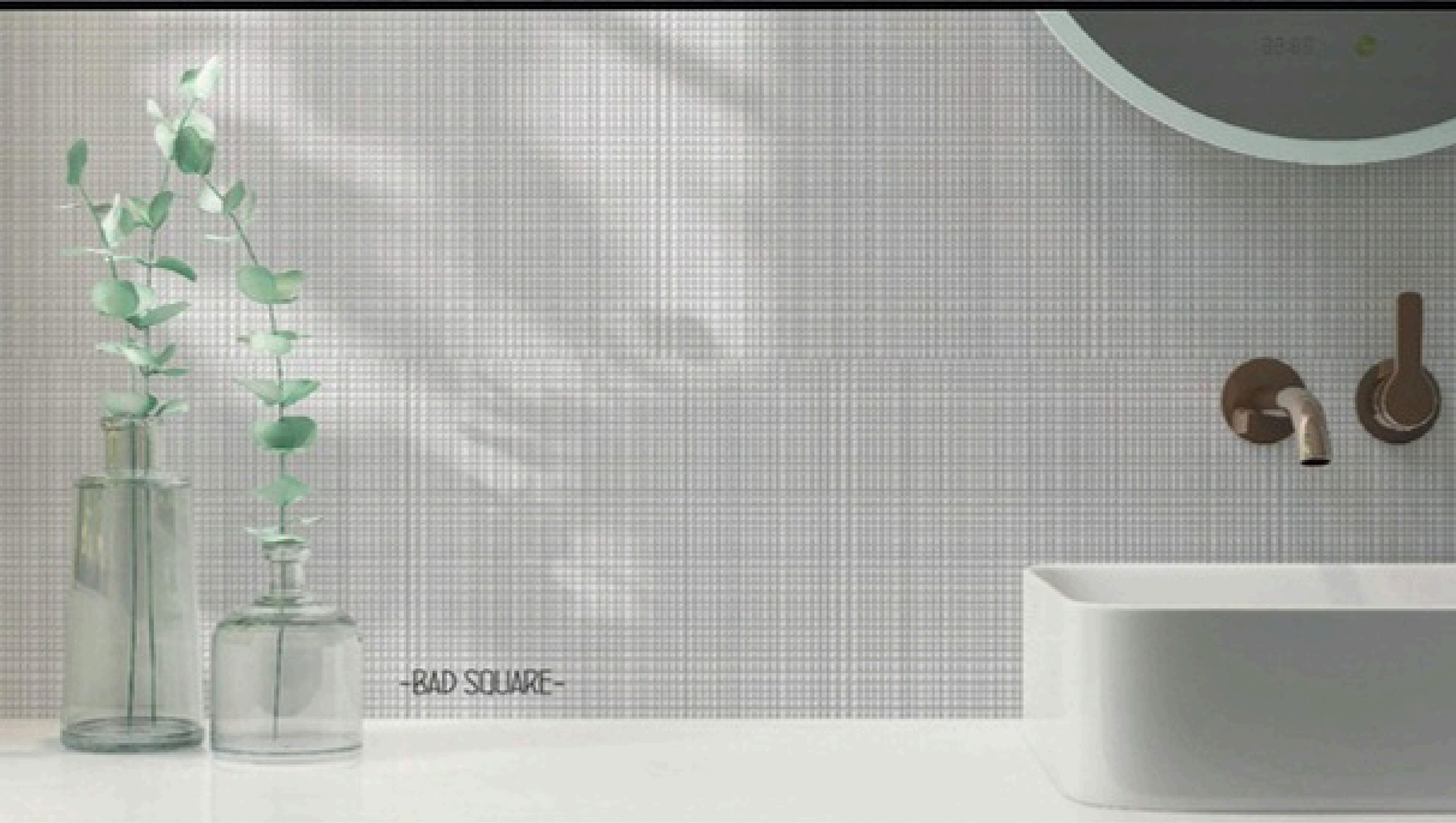

-BAD SQUARE-

STONEGLASS® Tiles

Tile's dimensions:

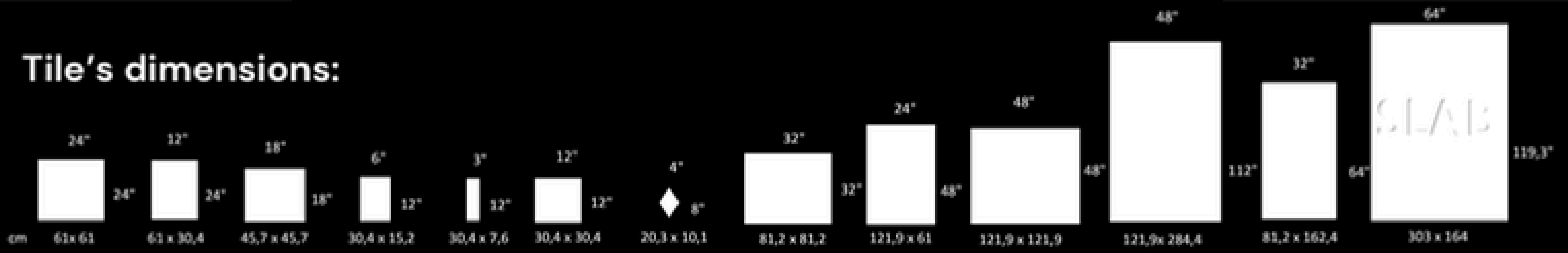

Misure personalizzabili su richiesta / Customizable sizes upon request

Esempi di mosaici / Example of mosaics

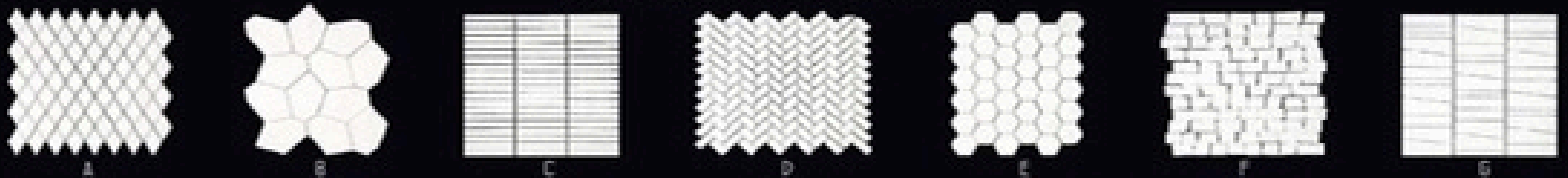

RETRO ILLUMINABILE
BACKLIT

Finishes:

LUCIDO/POLISH



MATT



ANTISCIVOLO



	Wet Dynamic	
	Coefficient of Friction (DCOF)	
	Polished	0.50
	Matt	0.59
	Antiscivolo	R11
Mohs Scratch Hardness 7		

SIRE

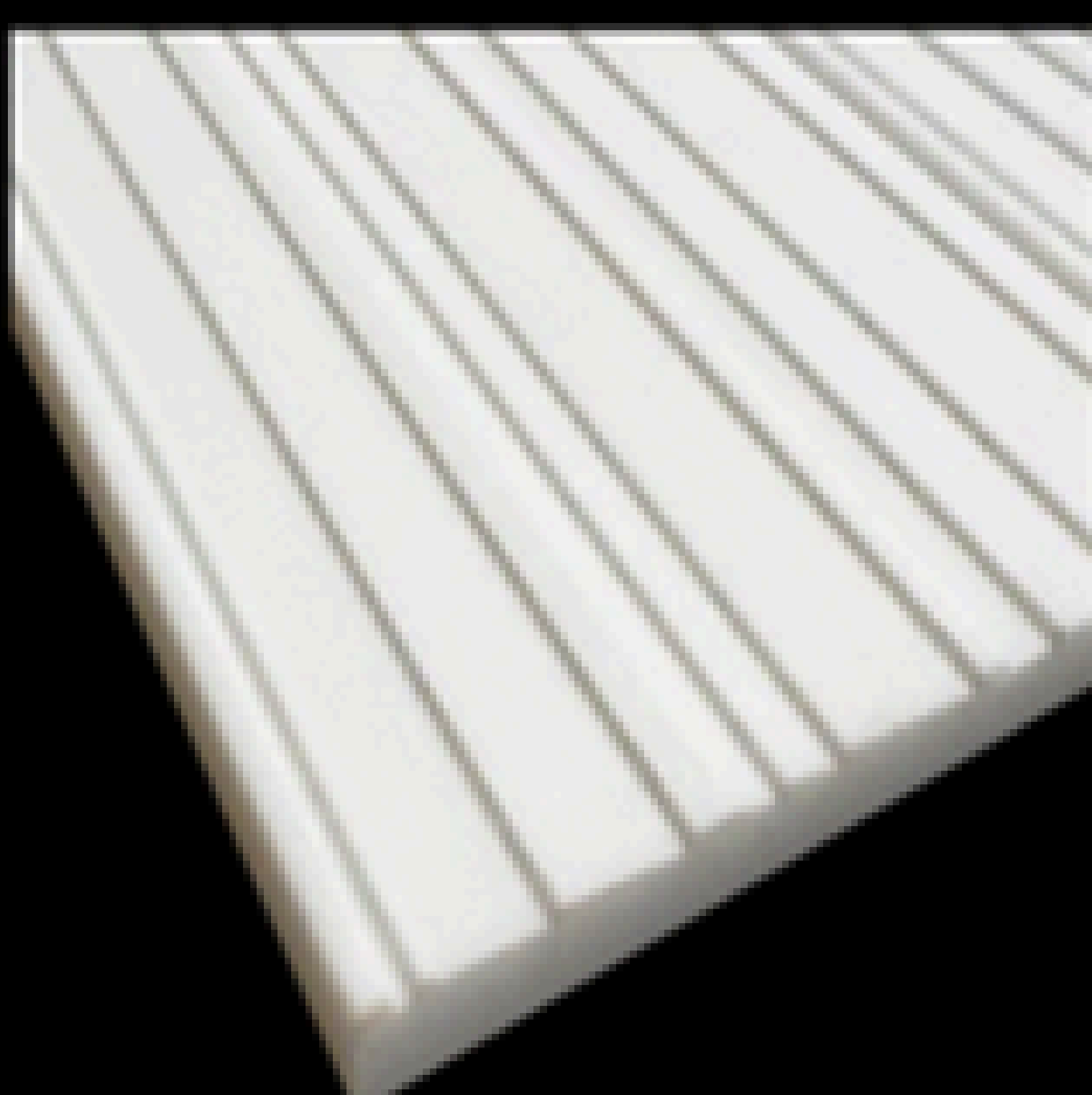

SIRE 2.0"

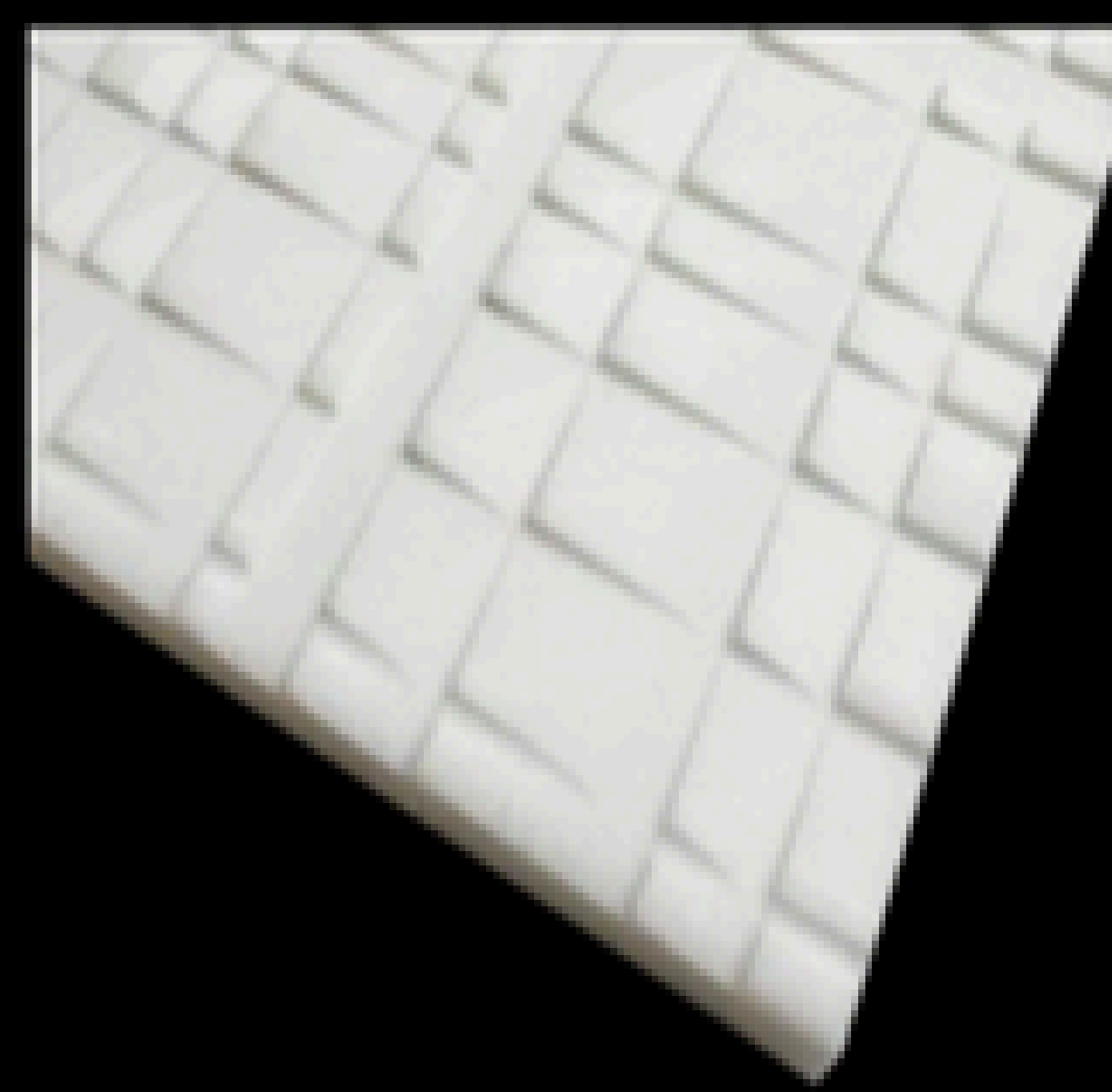

BAD SQUARE

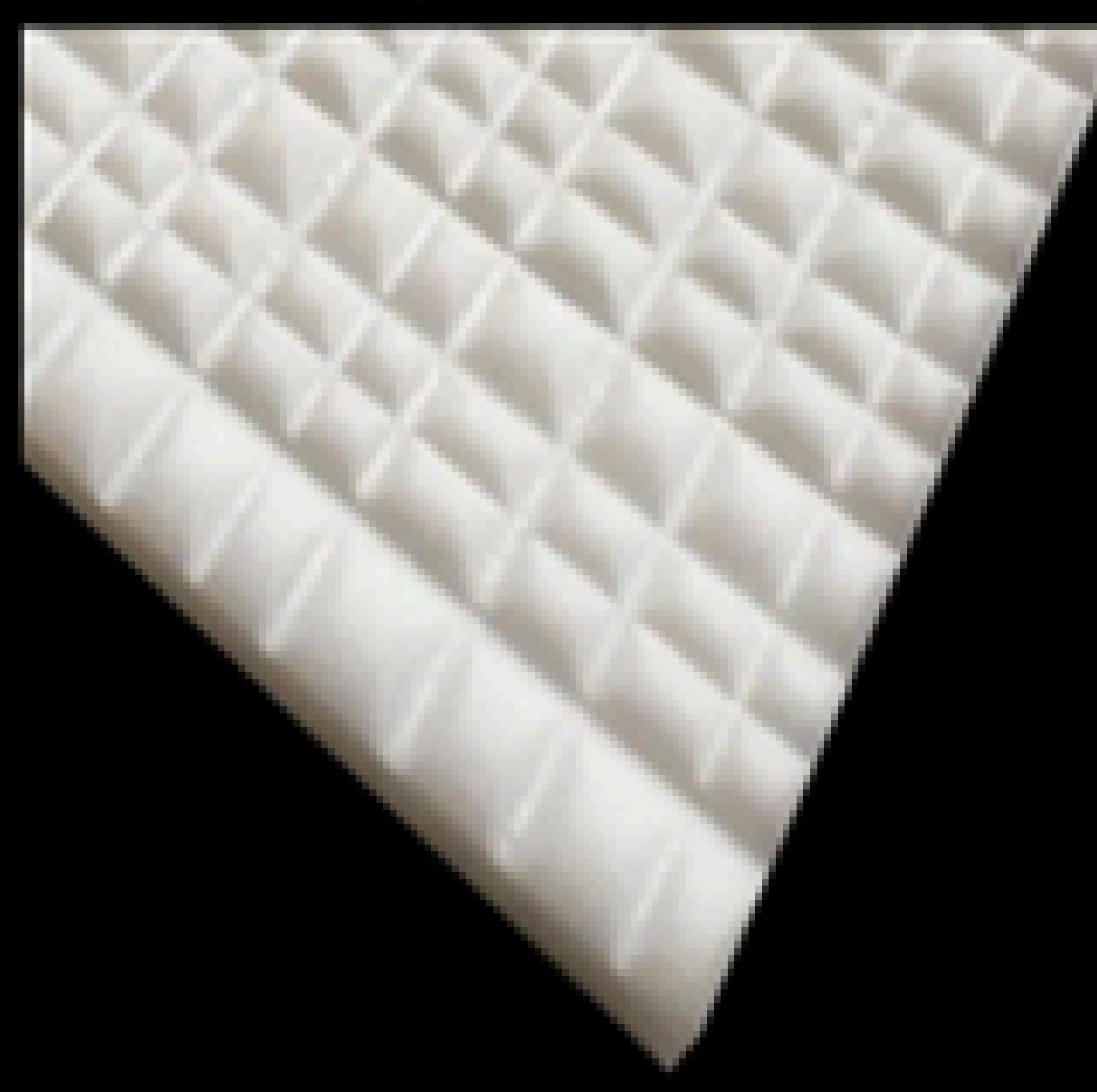

BAMBU'



STONEGLASS®

Material Comparison

 **Excelent**

 **Good**

 **Fair**

 **Poor**

Material	Scratch Resistance	Impact Resistance	Acid Resistance	Stain Resistance	Heat Resistance	Maintenance	Low Porosity Compactness
MICROGLASS							
Glass							
Engineered Stone Agglomerate							
Sintered Stone (matte finish)							
Sintered Stone (polished finish)							
Natural Stone: granite, porphyry							
Natural Stone: marble travertine							
Solid Surface							
Hpl							
Metal							
Wood							





info@stoneglass.it
www.stoneglass.it